

H-Base Stands

CTM **INTEGRATION INC.**
Labeling Systems Built to Last



Innovations in Labeling
www.ctmlabelingsystems.com

H-Base Stands

Features:

Heavy duty one-piece base construction of welded carbon steel tubing.

Vertical upright construction of .250" wall DOM Steel tubing.

Patented internal assembly designed for ease of vertical height adjustment.

Traverse construction of Thomson bearings and rails.

Traverse assemblies are equipped with a "half nut" feature allowing both "quick positioning" and "fine adjustment."

All carbon steel components are coated with a rust inhibitive primer and finished with "Steel It" polyurethane paint.

All aluminum parts are anodized.

Stands are supported on 4" diameter locking casters (leveling pads are optional.)

Options:

- Low profile base enable the stand to nest under forms feed tables or other product conveyors with space restrictions.
- Dual X&Y-axis traverse slide for optimum adjustment capability
- Yard arm
- Airlift kit
- Leveling Pads
- Extended upright
- Extended slot
- Double internal
- Drop-down tie plate
- Control Shelf
- Custom mounting stands

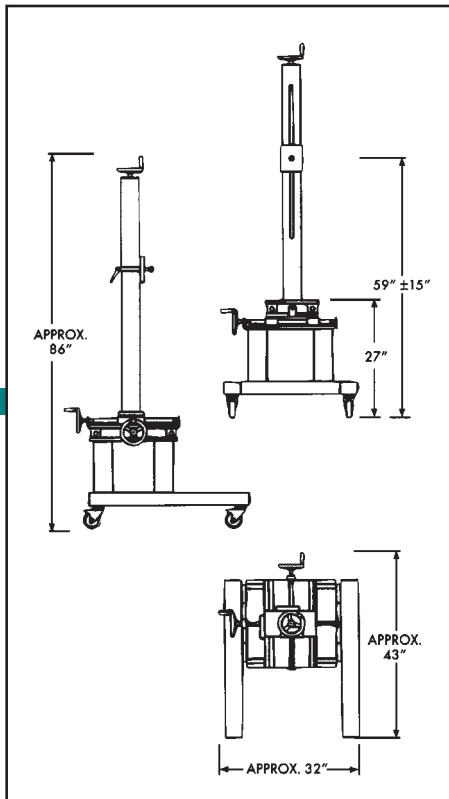

Double Traverse H-Base

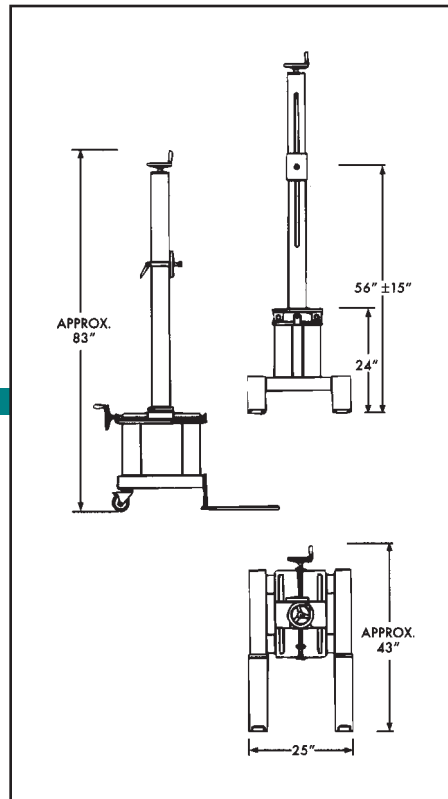

Low-Profile H-Base

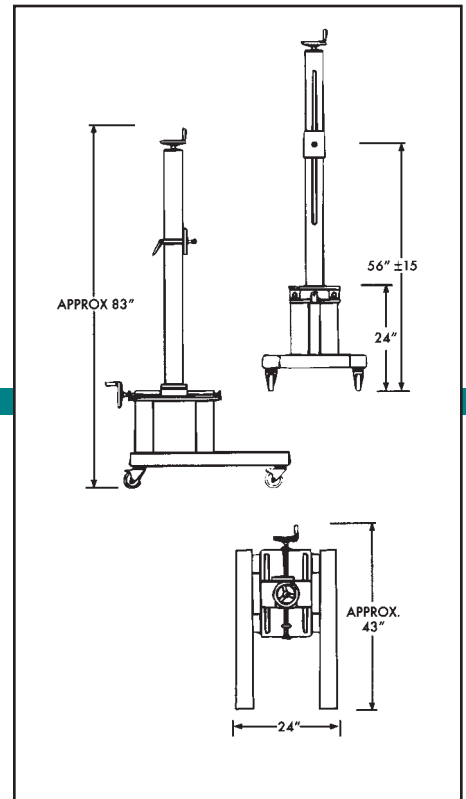

Single H-Base

QLC

537 Progress Drive
Hartland, WI. 53209
Phone: (262) 367-1400
Fax: (262) 367-1405
Toll Free: (800) 837-1309
Email: info@qlc-labeling.com



1318 Quaker Circle
P.O. Box 589
Salem, Ohio 44460
(330) 332-1800

www.ctmlabelingsystems.com