

The Hugger System

Proven Performance

The QLC Hugger System fits virtually any applicator or printer applicator. It also accommodates all label and product sizes. Nutritional and safe handling information can be applied at production speeds to both sides of the product simultaneously. This makes the Hugger System particularly ideal for the food industry.

More than 40 years of labeling experience and 15 years of building quality **top and bottom** labeling systems have provided us a proven track record. And now another great product from QLC!

Utilizing thin, side-driven hugger belts, the Hugger System adjusts in width up to 9½" (standard) to accommodate a variety of products. Product transfers easily from your conveyor into the hugger. High friction belts and sturdy rails grab, hug and secure the product at speeds up to 160 feet per minute providing accurate label placement from any type of label applicator.

The system is user friendly and adjusts very easily for different width products. The Hugger has a small footprint yet provides easy access to the labelers. Labelers are mounted on a heavy-duty frame, which features leveling screws and locking casters for ease of mobility. Additionally, the system's corrosion resistant electrical enclosure and rugged 4" x 4" tubing make it ideal for any production environment.

Consider these additional features of the Hugger System:

- Constructed with high quality materials
- Designed to fit into minimal space requirements
- Engineered for a wide range of products
- Customized to meet all of your top and bottom labeling requirements

Shown with stainless steel and optional mounting for a fifth labeler

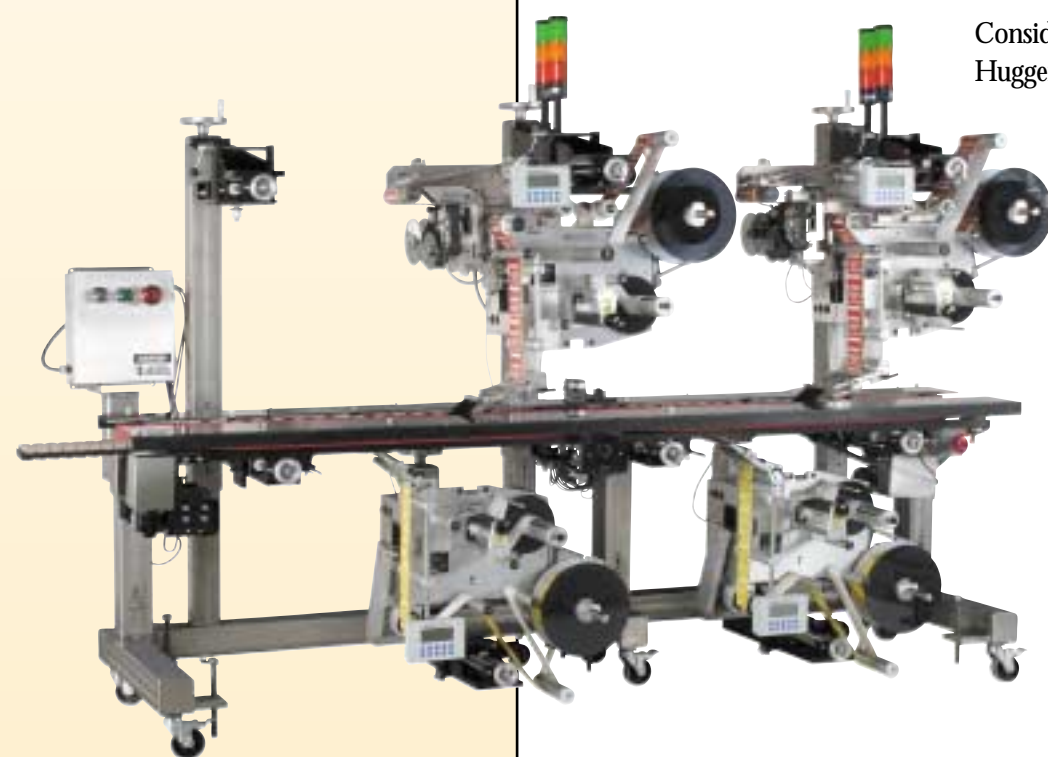
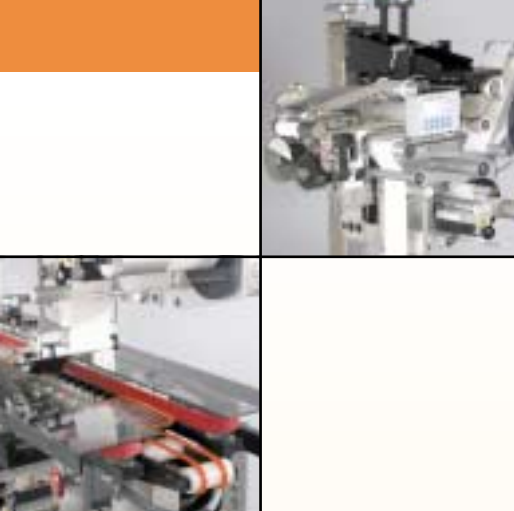



Specifications

Opening: Up to 9½"

Conveyor height: 36" +/- 3"

Machine width: ~36"
dependent on product width

Machine length: See below

Power requirements: Labeler dependent

QLC Single Hugger System

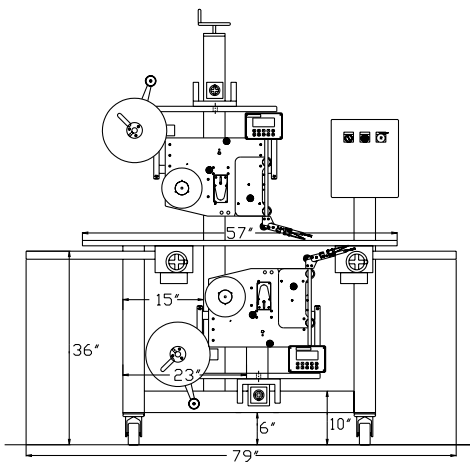

QLC Dual Hugger System

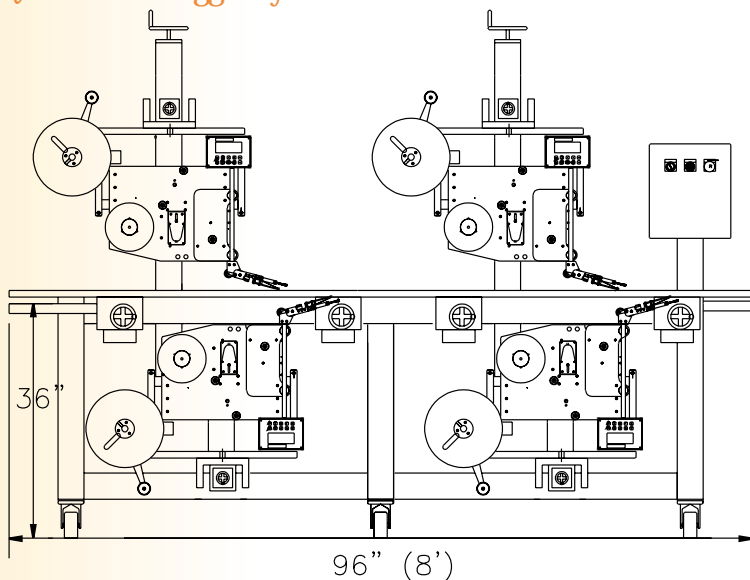

Features

- Heavy-duty, painted steel construction
- 4" x 4" tubing
- Emergency stops at each end
- Guarded motors and pulleys
- Leveling screws and locking wheels
- Operator friendly, easily adjusted
- Adjustable up to 9½" wide products
- Handles up to almost any length product
- Corrosion resistant electrical box
- High friction belts
- Accommodates any manufacturer's applicator
- Right to left or left to right product flow

Options

- Stainless steel construction
- Powered in-feed and out-feed conveyors
- Roller rail supports
- Multiple labelers for zero downtime
- Customization is always available
- Powered vertical adjustment

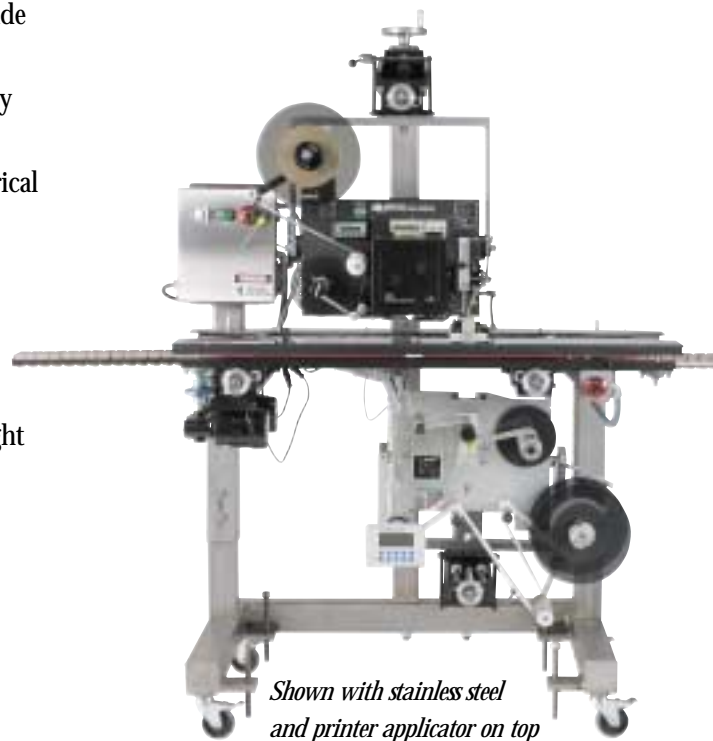

Shown with stainless steel and printer applicator on top

QLC is a factory authorized distributor, supplying high quality labeling equipment, printer/applicators, service and parts. Some of our lines include Label-Aire®, CTM Integration, CVC Technologies, Vitof and PAGO. QLC sells, rents and services pressure sensitive labeling equipment in addition to offering in-house contract labeling.

QLC, INC.

537 Progress Drive • Hartland, WI 53029
 (800) 837-1309 • (262) 367-1400
 (262) 367-1405 FAX
www.qlc-labeling.com