

Model 3125



3125 Wipe-On

Primary Applicator

Model 3125

The **Label-Aire® Model 3125** makes labeling easier and faster... making you more profitable.

The Model 3125 Wipe-On labeler delivers on its promise of speed, accuracy, and ease of use. And that translates into lower operating costs and increased productivity for your business.

Speeds up to 2,500 inches (6,350 cm) of web per minute make the Model 3125 an ideal choice for demanding applications requiring high speed and precision. Advanced features include Automatic Speed Following (ASF) which allows product surface profiling, ensuring wrinkle-free labeling on even the most difficult product shapes and label materials (optional encoder required). Zero Downtime Labeling allows your production to continue without costly interruptions. Product/label queuing and missing label compensation virtually eliminate unlabeled products or missing lot and expiration codes.

Put this high-speed wipe-on pressure-sensitive technology to work for you all day, every day. The Model 3125 Wipe-On labeler is built to meticulous quality standards and designed to withstand the most intense operation.

3125 Wipe-On Advanced Features	
Automatic setup	Includes multiple programmable label pages for easy changeovers to different label sizes.
Stepper motor drive	For precise starting / stopping, increased reliability, wider range speed variability, and lower maintenance.
R3 digital display	Select from five languages (English, French, German, Italian, Spanish), domestic or CE (European) configurations, standard/metric unit display and detailed alarm messages. Can rotate 360°.
Automatic Speed Following (ASF)	Labels are accurately applied even through extreme changes in product line speed.
Quick-action collapsible rewind	Allows easy removal of scrap liner.

Quick-action collapsible

High-Speed
powered

beverage, cd / dvd, coupon / promotional, dairy, direct mail, durable goods, food, health & beauty, nutraceutical, pharmaceutical, tamper-evident labeling



R3 digital display

Automatic setup

Intelligent controller

Loop box



Visible rewind

Speed, High-Torque VFD
and unwind

Advanced Automatic
Speed Following

Standard dispense speeds up to
2,500" (6,350 cm) per minute

Label placement accuracy
up to +/- 1/64" (.4 mm)

Wipe-on applicator available
left- or right-hand configurations

3125 Wipe-On Specifications

Dimensions:

Height: 33.95" (862.4 mm)
Length: 36.54" (928.03 mm)
Width: 26.61" (675.93 mm)

Weight:

160 lbs. (73.6 kg)

Standard Label Dimensions:

Max. Web Width: 7.13" (181 mm)
Min. Web Width: 1" (25 mm)
Min. Label Length: .5" (13 mm)

Label Packaging:

16" (406 mm) O.D. rolls std. on
3" (76 mm) I.D. cores with
optional 6" (152 mm) core adapters

Dispense Speed:

2,500" (6,350 cm) of web per minute

Label Placement Accuracy:

Up to +/- 1/64" (.4 mm)

Electrical:

115 Volts AC 60 Hz 3 Amps.
220 Volts AC 50 Hz optional

Options:

6" (152 mm) label core adapter
Encoder kit for Automatic
Speed Following
Strobe signals for "low label" and
"out of labels"
Clear label sensor upgrade
Hot stamp imprinter
Display tilt mounting brackets
Model 2700 T-Base stand
Consult factory for additional options.

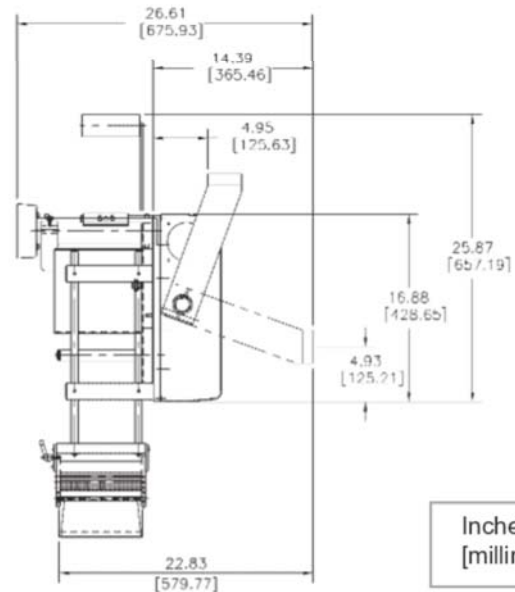
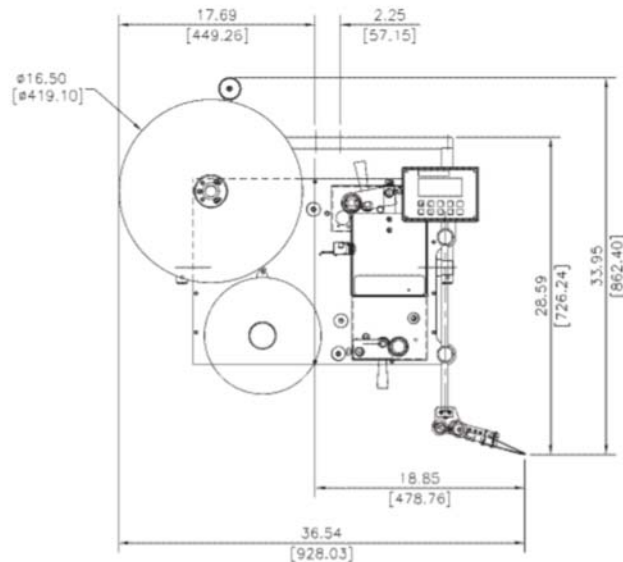

Inches
[millimeters]



QLC

537 Progress Drive
Hartland, WI. 53209
Phone: (262) 367-1 400
Fax: (262) 367-1 405
Toll Free: (800) 837-1 309
Email: info@qlc-labeling.com