

Model 315-NV



3115-NV Wipe-On

Primary Applicator

The Label-Aire® Model 3115-NV makes labeling easier and faster...making you more profitable.

The Model 3115-NV Wipe-On labeler delivers on its promise of speed, accuracy, and ease of use. And that translates into lower operating costs and increased productivity for your business.

The Label-Aire Model 3115-NV was designed for high-speed wipe-on labeling applications at a standard dispense speed of up to 1,500" (38.1 m) of web per minute or up to 2,000" (50.8 m) with the optional powered rewind. Advanced features include Velocity Compensation for improved label placement accuracy, a microprocessor controller with digital display, and ambidextrous parts. Zero Downtime Labeling allows your production to continue without costly interruptions. Missing label compensation virtually eliminates unlabeled products. Furthermore, the 3115-NV comes standard with a heavy duty double stack stepper motor—at no extra charge. Not only can the 3115-NV be easily converted to left- or right-hand use, it can also apply labels to the top, side, or bottom of products with a label dispense accuracy of up to +/- 1/32" (.8 mm). Adding to the 3115-NV's versatility are the availability of tamp-blow and air-blow conversion kits.

Put this wipe-on pressure-sensitive technology to work for you all day, every day. The Model 3115 Wipe-On labeler is built to meticulous quality standards and designed to withstand the most demanding operation.

QLC, Inc. (800) 837-1309



3115-NV Wipe-On Specifications

Dimensions:

Height: 33.2" (843.2 mm)
 Length: 39.94" (1,014.5 mm)
 Width: 25.08" (637.1 mm)

Weight:

145 lbs. (65.7 kg)

Standard Label Dimensions:

Max. Web Width: 7.13" (181 mm)
 Min. Web Width: .63" (16 mm)
 Min. Label Length: .5" (13 mm)

Label Packaging:

16" (406 mm) O.D. rolls std. on
 3" (76 mm) I.D. cores
 20" (508 mm) powered rewind and
 powered unwind

Dispense Speed:

Up to 1,500" (38.1 m) of web per
 minute (standard)
 Up to 2,000" (50.8 m) of web per
 minute with smart powered rewind

Label Dispense Accuracy:

Up to +/- 1/32" (.8 mm)

Electrical:

115 Volts AC 60 Hz 3 Amps.
 220 Volts AC 50 Hz optional

Air (as needed):

2 cfm at 60 psi to 90 psi when
 imprinter is used

Options:

Smart 10" (254 mm) powered rewind
 Smart 20" (508 mm) powered unwind
 and powered rewind*
 6" (152 mm) label core adapter
 Encoder kit for Automatic
 Speed Following
 Strobe signals for "low label" and
 "out of labels"
 Clear label sensor upgrade
 Hot stamp imprinter
 Display tilt mounting brackets
 Model 2700 T-Base stand

Consult factory for additional options.

*4.13" (105 mm) wide applications only

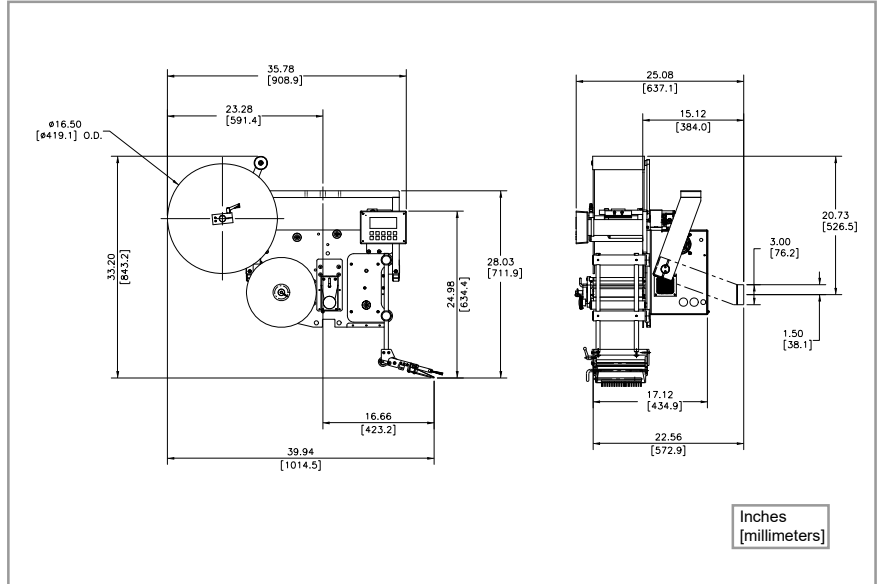

Stated dimensions are approximations. Please consult factory if dimensions are required for line integration.

3115-NV Wipe-On Advanced Features

Automatic setup	Includes multiple programmable label pages for easy changeovers to different label sizes.
Stepper motor drive	For precise starting/stopping, increased reliability, wider range speed variability, and lower maintenance.
R3 digital display	Select from five languages (English, French, German, Italian, Spanish), domestic or CE (European) configurations, standard/metric unit display and detailed alarm messages. Can rotate 360° in 90° increments.
Automatic Speed Following (ASF)	Labels are accurately applied even through extreme changes in product line speed.
Optional quick-action collapsible rewind	Allows easy removal of scrap liner.
Optional smart powered rewind	For dynamic web tension control.
Wipe-On applicator	Easily adapts to air-blow or tamp-blow use.

QLC, Inc.

537 Progress Drive
 Hartland, WI 53029
 www.qlc-labeling.com

(800) 837-1309

