

the team to trust ■ ■ ■

user manual ■ ■ ■

SmartDate X60

Colour user Interface



User Documentation - Interface Design team

en

Revision AA



10056272

www.markem-imaje.com

Markem-Imaje Limited
Nottingham Science Park
University Boulevard
Nottingham NG7 2QN
Tel.: +44 (0)115 943 0055



markem·imaje

A **DOVER** Company



markem·imaje

A **DOVER** Company

for parts & service call QLC (800) 837-1309

General	15
■ Introduction	17
■ Copyright Notice	17
■ Contact	18
■ Related Documentation	18

Contents

Description	19
■ Introduction	21
■ Overview	22
■ SmartDate X60 Model Options	23
■ Main Components	24
Key Features	24
■ Printer Types	25
SmartDate X60 - Intermittent Mode	25
SmartDate X60 - Continuous Mode	25
SmartDate X60 Shuttle Continuous Printer	26
■ Print Designs	27
CoLOS Create pro	28
Supported Field Types	29
SmartDate X60 and Fonts	29
■ Image Template Files	30
■ Device Settings Files	31
Jobs	32
■ Retrieving and Downloading Jobs	33
Data Storage Capacity	33
■ Using a USB Memory Stick	34
Downloading Images	34
■ Labels and Symbols	36
■ Beacon Light	37

Interface	39
■ Introduction	41
■ The User Interface Panel	42
LCD Screen	43
■ Keypad	44
■ Screen Icons	45
■ Screen Types	47
Example of Menu Screen Layout 1:	48
Example of Menu Screen Layout 2:	49
Example of Menu Screen Layout 3:	50
■ Home Screen	52
■ Security Login Screen	53
■ Security Options	54



Contents

■	Menu Screens	55
■	Data Entry Screens	56
	Prompted Data	56
	Alpha Data Entry Screens	57
	Numeric Data Entry Screens	57
	Language specific characters and symbols	58
■	Date Entry Screens	59
	Literal Date Entry	59
	Fixed Format Date Entry	60
	Calendar	60
	Offset Date Entry	61
■	Diagnostics Screens	62
■	Reports Screens	63
■	Special Screens	64
	Ribbon Type Verification	64
	Faults and Warnings Alert Screens	65
	Failed Prints	66
	Dead Dot Detection	67
■	Power saved mode	68



Operation	69
■ Introduction	71
■ Start the printer	72
Home Screen	72
■ Stop the printer	73
■ Information	74
Counts	75
Supplies	76
Health	77
The Health Screen	79
The Availability Log Screen	80
The Printhead Information Screen	81
Identity	82
Usage	83
Dot Check History	83
Firmware History	83
Job History	84
■ Print Adjust Screen	85
Print Darkness	85
Offset	86
Registration	87
Test Print of the Current Job	87
Rotation	88
Adjust Image	88
■ Removing the cassette	90
■ Loading or Replacing the Ribbon	91
Removing Waste Ribbon from the Waste Take up Core	91
■ Loading a New Ribbon	92
Re- Connecting a Broken Ribbon	94
Cassette Webbing Diagrams	95
Replacing the Cassette	96
■ Principles of Printing	97
Thermal Transfer Technology	97
Print Process	98



Contents

■	Operating Principles	100
	Print Cycle SmartDate X60 - Intermittent Printer	101
	Print Cycle SmartDate X60 - Continuous Mode Printer	102
	Print Cycle SmartDate X60 - Shuttle Continuous Printer	103
■	Operating Modes	104
	Non-Ribbon Save Modes	104
	Ribbon Save Modes	104
■	Printer Specific Print Options	105
	SmartDate X60 - Intermittent mode	105
	SmartDate X60 - Continuous mode	105
	SmartDate X60 - Shuttle Continuous	105
■	High Pack Rate Mode	106
■	High Speed Mode	107
	High Speed Options	108
	Threshold (ON/OFF)	108
	Materials and Applications	109
	Limitations	110
■	Interlace Mode	111
	Setting up Interlace Mode	112
	Materials and Applications	113
	Limitations	113
■	Radial Ribbon Save Mode	114
■	Cost Saving Mode	115
■	Relative Motion	119
■	Low Speed Print Mode	122
	None	122
	Continue	123
	Reprint	123



Job selection	125
■ Introduction	127
■ Job Setup Screens	127
■ Job Setup Menus	128
Job Setup using the Default Print Design.	128
Using CoLOS Create Pro	130
Job Setup using the Local Database	131
Filtering the list of Job names	133
Job Setup using a Host PC	134
Prompted Data	136
■ Date Entry Screens	137
Literal Date Entry	137
Fixed Format Date Entry	138
Calendar	138
Offset Date Entry	139
■ Print Preview	140
■ Master-Slave Function	141
■ Connecting Masters to Slaves	142
■ Configuring the System	142



Contents

Printer configuration	143
■ Introduction	145
■ Accessing the Menus	146
■ Settings Constraints	151
■ Settings Menus	153
■ Machine Settings	155
Machine Options	156
Image	158
Print Features	160
Print Initiation	161
Print Quality	162
Encoder	164
Print Position	165
Ribbon Setup	166
Ribbon Monitoring	167
Communications	168
Speed Profile Recorder	169
NGPCL	170
Master / Slave	171
Logging	171
SSCC	172
External	172

■ Display Settings	173
■ Adjust RTC (Real Time Clock)	174
■ Language	175
■ Security	176
User accounts	176
■ Time/Date Codes	177
■ Flexible I/O Map	177
■ Diagnostics	178
Diagnostics	178
■ Statistics	178
■ Files	179
■ Service	179
■ Version Information	180



Contents

Diagnostics	181
■ Introduction	183
■ Diagnostics	184
Diagnostics	184
Printer	185
Inputs Status	186
Outputs Status	186
Temperatures	187
Print Timing	187
Ribbon	188
Internal	189
■ Manual Control	191
Ribbon	192
Printhead	192
■ Digital IO Control	193
■ Select Test Pattern	193
■ Speed Profile	194
Interpreting the graph	196



History **199**

- **Statistics** **201**
- **Statistical Information** **202**
 - Printhead Life 202
 - Ribbon Usage 202
 - Printer Usage 202
 - Throughput 203
 - PackML State Times 203

Maintenance **205**

- **Introduction** **207**
- **Cleaning and Care** **207**
- **Maintenance Scheme** **208**
 - Quick/Regular Checks 208
 - Monthly Checks 209
 - Care of the Printhead 209
- **Cleaning the Printhead** **210**
- **Replacing the Printhead** **211**
 - Removing the damaged printhead (Combined) 211
 - Removing the damaged printhead (Shuttle) 213
 - Setting the correct printhead resistance 215
- **Replacing the Peel Roller** **217**
- **Replacing the Ribbon Guide Rollers** **221**
- **Replacing the Ribbon Movement Roller** **223**
 - Replacing the Roller Magnet 223
 - Replacing the Movement Roller 225
- **Replacing the Ribbon Tension Roller** **227**

Contents

External links 229

- **Controller and Printer Connection Points** 231
 - Printer 232
- **Printer Power and Control Signals** 233
 - Control I/O Connections 234
 - Print Go Input Wiring 235
 - Fault and Warning Outputs 236
- **Encoders** 237
 - Quadrature Encoders 238
 - Encoder Resolution 239
 - Single Channel Encoders 240
 - Fixed Speed settings 240
- **Communication Links** 241
 - NGPCL Communication 241
- **Communication Options** 242

Technical specifications 243

- **Machine Specification** 245
 - SmartDate X60 245

General



General

CAUTION : Before using this printer, please read and fully comply with these instructions, the material safety data sheet (MSDS) for consumables used.

■ Introduction

This Manual along with the SmartDate X60 Instruction Booklet, set out to explain how to safely install, operate and service your SmartDate X60 Overprinters.

The Operator Manual is available in Adobe Acrobat PDF in various languages on the SmartDate X60 CD.

The manual format is designed to be printed onto 8» x 11» (203mm x 279.5mm) paper, but can also be printed onto 8.5» x 11» (216mm x 279.5) (Previous MARKEM manual paper size) or A4 (210mm x 297mm)

Alternatively a Hard bound copy of the manual can be purchased separately from Markem-Imaje.

Please contact your local supplier for details.

■ Copyright Notice

Original Copyright © 2005 Markem-Imaje. All rights reserved.

Reproduction of any or part of this manual in any form whatsoever without the expressed written permission of Markem-Imaje is forbidden. The contents of this manual are subject to revision without notice.

All efforts have been made to ensure the accuracy of the contents of this manual.

However, should any errors be detected, Markem-Imaje would greatly appreciate being notified.

Markem-Imaje make no warranty of any kind with regard to this material, including, but not limited to, the implied warranties and fitness for purpose. Markem-Imaje shall not be liable for any errors contained in this material or for incidental or consequential damages in connection with the furnishing, performance, or use of this material.

The use of non genuine Markem-Imaje consumables and spare parts may adversely affect the performance of the product and could invalidate the warranty.

Copyright © 1995 - 2011 Markem-Imaje Corporation.

■ Contact

Thank you for choosing Markem-Imaje to provide printing solutions. If questions should arise, please contact the local business centre that assisted with your purchase.

Markem-Imaje LTD
Nottingham Science Park
University Boulevard
Nottingham NG7 2QN
United Kingdom
Tél. : (44) 0115 943 0055
Fax : (44) 0115 968 3699
<http://www.markem-imaje.com>

■ Related Documentation

Below is a list of documents in the SmartDate X60 related documentation set.

CoLOS Create Pro
CoLOS Control
DCP (Device Communication Protocol)
NGPCL (Next Generation Print Control Language)
Ethernet
Customer Configurable I/O

Useful Web Sites
www.markem-imaje.com
www.myMARKEM.com

Description



Description

■ Introduction

This section provides an overview of the main features of the SmartDate X60.

Topics covered in the section include:

- Overview.
- SmartDate X60 Model Options.
- Main Components.
- Key Features.
- Printer types.
- Print Designs.
- CoLOS Create Pro.
- Image Template Files.
- Device Settings Files.
- Jobs.
- Retrieving and Downloading jobs.
- Labels and Symbols.
- Beacon Lights.



Description

■ Overview

SmartDate X60 is a small easy to use electronic coder. The two models available are designed to be suitable as a direct replacement for many different methods of coding.

SmartDate X60 consists of a printing device and a control device with an operator interface control panel.



SmartDate X60 prints batch codes, best before dates and other variable information directly onto packaging, substrate and other materials. The size, position and content of information can be fixed or altered at the SmartDate X60 user interface.

■ SmartDate X60 Model Options

The SmartDate X60 is available in two printer types.

- SmartDate X60 Combined-Intermittent / Continuous (No Shuttle)
- SmartDate X60 Continuous.with shuttle

The type of model required is dependent on the application.

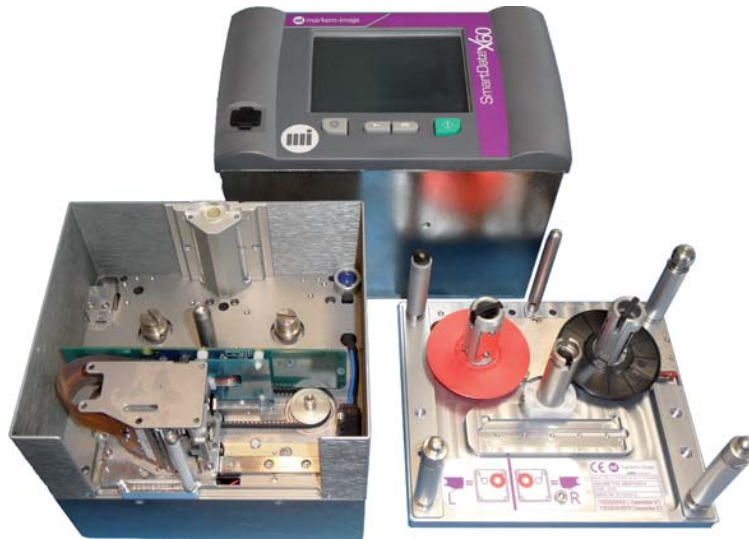

SmartDate X60 - Combined Intermittent / Continuous

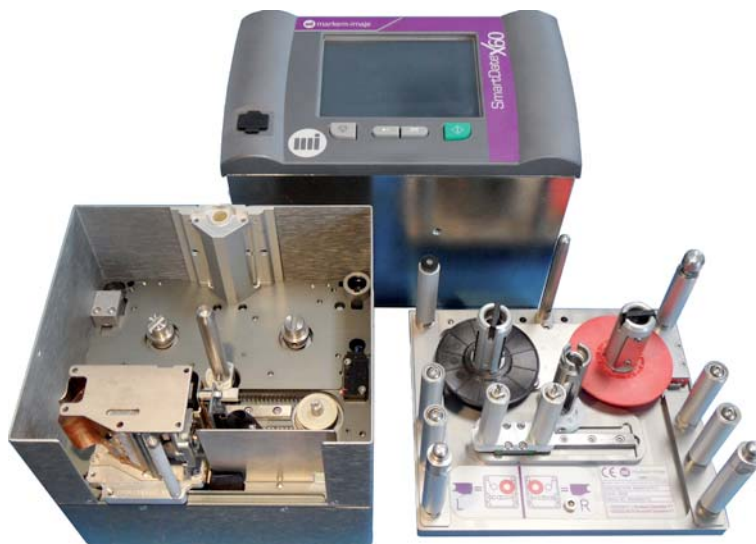

SmartDate X60 Continuous with shuttle

Description

■ Main Components

The main components of the SmartDate X60 are as follows:

- Printer body unit containing drive system and thermal transfer printhead.
- Printer body cassette with ribbon supply and waste take up.
- Controller unit containing main operation PCBs and User Interface.
- Connecting cable for printhead power and control.
- Connecting cable for External I/O signals.
- Air supply connections for printhead operation.
- Encoder for substrate speed tracking.

▣ Key Features

- **Cassette Ribbon Loading:** using an easy to load Printer Cassette reduces line down-time when changing consumables.
- **Efficient Ribbon Usage:** SmartDate X60 automatically controls the ribbon feed, no manual adjustment is required, minimising ribbon usage. See Printer Parameters, for further details.
- **Advanced Ribbon Length: (ARL)** - available both models: SmartDate X60 now has the capacity for a 1100 metre length of ribbon, thus allowing for fewer ribbon changes, subsequently resulting in less downtime.
- **Self aligning printhead:** The print platen/roller does not require precise alignment to the printhead, therefore reducing the need for periodic adjustment.
- **Continuous Motion Version:** SmartDate X60 (Continuous Mode) has accurate tracking of the substrate speed and sophisticated control of the printhead and ribbon feed provides the best possible print quality.
- **Reduced set up / down time:** The printhead data is changed at the control panel.
- **High Reliability:** the Markem-Imaje experience of thermal printing and the latest design eliminates the need for complex mechanical maintenance procedures.
- **Flexibility:** the control system allows product data to be stored in local memory or set remotely by a host PC or another computer.
- **Networking:** support for the Markem-Imaje Ethernet CoLOS Control Network is provided to allow centralised set up and control of a number of SmartDate X60 machines from a central PC or centralised data storage.

■ Printer Types

▣ SmartDate X60 - Intermittent Mode

This version is used with intermittent motion packaging machines and prints onto the material when it is stationary.

The SmartDate X60 printer in this mode has a print area of 53mm x 75mm and print speed of 70 to 700 mm/s.

Moving the print-head during the dwell time when the packaging material is stationary prints the information.

The SmartDate X60 printer in intermittent mode prints text and bar codes at any position within the 53mm width by 75mm length print area.

SmartDate X60 uses a thermal print-head and thermal ink ribbon to print information onto materials held against a flat print platen.

▣ SmartDate X60 - Continuous Mode

This version of the SmartDate X60 printer is designed to print on to moving substrate.

The SmartDate X60 printer in this mode has a print area of 53mm x 150mm and print speed of 30 to 1000 mm/s.

When in continuous motion mode the print-head is held in a fixed position and the ribbon is accelerated to match the substrate speed.

An encoder is used to establish the speed of the material being printed onto.

This makes it the ideal coder for continuous motion form fill and seal machines and horizontal flow wrappers, where larger images are required and fast print speeds are not an issue.

The SmartDate X60 printer in this mode prints text and bar codes at any position within the 53mm width by 150 mm length print area.

SmartDate X60 uses a thermal print-head and thermal ink ribbon to print information onto materials held against a print roller.



Description

■ SmartDate X60 Shuttle Continuous Printer

This version of the SmartDate X60 printer is designed to print on to moving substrate. The SmartDate X60 has a print area of 53mm x 100mm and print speed of:

30 - 700 mm/s - High Pack Rate mode

30 - 1000 mm/s - High Speed mode

30 - 1800 mm/s - Digital Ribbon Save (DRS) mode.

The print-head assembly has no linear motion, the ribbon is accelerated to match the substrate speed.

An encoder is used to establish the speed of the material being printed onto.

This version of the SmartDate X60 printer uses a ribbon shuttle mechanism similar to SmartDate5c to attain the higher speeds required.

This makes it the ideal coder for continuous motion form fill and seal machines and horizontal flow wrappers, where the image size is below 100mm in length and high speed is an issue.

The SmartDate X60 prints text and bar codes at any position within the 53 mm width by 100 mm length print area.

SmartDate X60 uses a thermal print-head and thermal ink ribbon to print information onto materials held against a print roller



■ Print Designs

Basic designs can be created at the SmartDate X60 user interface using up to 4 lines of text. The size and type of font is limited to 8 point Arial Bold.

The number of characters supported by the SmartDate X60 LCD screen is limited to approximately 104.

SmartDate X60 supports Unicode characters and the user now has a wide choice of language, although this may be limited to a Sub set of 128 characters.

This type of design does not support live updates, such as Time and Date fields, Best before Dates or Shift Codes.

For details see Section 4 - Machine Operation.

In addition, you can create your own designs on a PC using the Markem-Imaje CoLOS Create Pro software.

These designs are then loaded into the SmartDate X60 using the Markem-Imaje CoLOS Create Pro / CoLOS Control software.



Description

▣ CoLOS Create pro

The designs printed by SmartDate X60 can be created using the Markem-Imaje CoLOS Create Pro software.

N.B. Composer 5.XXX is not compatible with SmartDate X60, as these machines use Markem-Imaje NextGen Software for operation.

CoLOS Create Pro allows text, bar codes and graphics to be placed onto the SmartDate X60 print area. A brief description is given here relating to how CoLOS Create Pro operates in conjunction with SmartDate X60.

For further details refer to the Markem-Imaje CoLOS Create Pro Help Files.

CoLOS Create Pro deals with two types of information:

Image Templates and Job information.

Image Template files define the type, size and number of items, or fields, to be printed.

Job information stores fixed information specific to individual jobs.

This split of information is only important to users creating print designs. The SmartDate X60 itself generally deals with job information only, Image Templates are handled automatically.

▣ Supported Field Types

SmartDate X60 and CoLOS Create Pro for SmartDate X60 currently support the following field types:

- Text fields
- Bar codes
- Line fields
- Box fields
- Logo fields

SmartDate X60 and CoLOS Create Pro for SmartDate X60 currently support the following field styles:

- Static Text
- User Input Text
- Time - Date including Offset Dates (BBE) and Shift Codes
- Merged Text
- Calculated Text
- Maths Text
- Machine Setting Text

▣ SmartDate X60 and Fonts

SmartDate X60 supports True Type Fonts.

The characters that can be used is limited only by the Unicode character set selected.



Description

■ Image Template Files

Image Templates are created using Markem-Imaje CoLOS Create Pro Image Design Software package.

When creating an Image Template the user can structure how the finished image will look.

The style and size of Font, the Bar code type if being used and other details about the image are established when creating the Image Template.

Example:



This information is then saved as a .ITF (Image Template File)
For full details about Image creation please consult the CoLOS Create Pro Help Files.

NOTE: If an image is downloaded from CoLOS Create Pro using the job name "Test Image" it is not available for selection from the Select Job menu.

■ Device Settings Files

These are the specific parameter settings for the device.

Settings files are normally attached to a Job file which is downloaded to a device.

The settings may include information such as Print Darkness levels or Date offset rules for a particular product.

The configuration of individual settings will depend on the printing conditions required for specific Jobs.

The substrate being used or the speed required for printing a particular Job may require the Device settings to be altered.

By attaching a Device settings file to a Job the SmartDate X60 is configured accordingly when the Job is selected.

Device settings can be adjusted at the SmartDate X60 user interface but Device settings files can only be created by connecting CoLOS Control. These files can then be saved as a .Settings file and can be attached to specific Jobs.



Description

▣ Jobs

SmartDate X60 uses Job Files.

Jobs are a combination of a Product Code, Image Template and a Device Settings File.

A Device Settings file is used to configure the device parameters to suit a particular set of conditions.

For example:

Job A may be printing onto a Polypropylene substrate at a relatively slow print speed.

Job B may be printing onto a Metalized Polypropylene substrate at a much faster print speed.

The **Printer** (Device) setup for each job will be different.

In many cases the Job may only require a default Image Template and default Device Settings File.

When a Job is downloaded to the SmartDate X60 the data is stored as a **.job** file and includes a **.image** file and a **.settings** file.

The **Job Name** would normally be the same as the Product Code but can be different if required.

This is the name that is requested when performing a **SELECT JOB** command. Job creation is performed with CoLOS Create Pro.

NOTE: When after selecting jobs in producing mode, there will be a short period of time (order of 1 sec) during which printing will be disabled while the system is updated to print the new image.

■ Retrieving and Downloading Jobs

Job information can be downloaded by 3 methods:

- Using CoLOS Create Pro software.
- Using CoLOS Control software (for networking) and a direct link to a PC.
- Using a USB Memory Stick

▣ Data Storage Capacity

The SmartDate X60 internal memory is capable of storing around 20 Mb. The number of Job Files that can be stored depends upon the complexity of the Image Templates and the number of logos and downloadable fonts used.

Job Files

Typically, the standard memory is enough to store more than 2000 Job Files. However when logos or downloaded fonts are used these can take up a great deal of memory and restrict the number of files that can be stored.

Font Files

A standard downloadable font file size is approximately 50 Kb but a Unicode Font file can be anything from 100 Kb up to 13 Mb dependant on the number of characters in the font file.

Logo Files

To estimate the memory a logo requires you need to know the width and height of the logo in dots (pixels) or in millimetres.

The approximate size in Bytes is:

$(\text{Width (mm)} \times \text{height (mm)} \times 12) / 8$

or $\text{width (dots)} \times \text{height (dots)} / 8$

Where SmartDate X60 dots/mm = 12 and 1 Byte = 8 bits



Description

■ Using a USB Memory Stick

After creating an Image for an SmartDate X60 printer using the CoLOS Create software package, use the “Print to File” option in the File menu. The file can then be copied onto a USB memory stick ready for transfer to the printer.

For full details about Image creation please consult the CoLOS Create Pro Help Files.

■ Downloading Images

Once you have loaded the USB memory stick with the required images you can download these to the SmartDate X60 local database.

1



Insert the pre-loaded USB memory stick into the USB connector on the front of the printer.

2

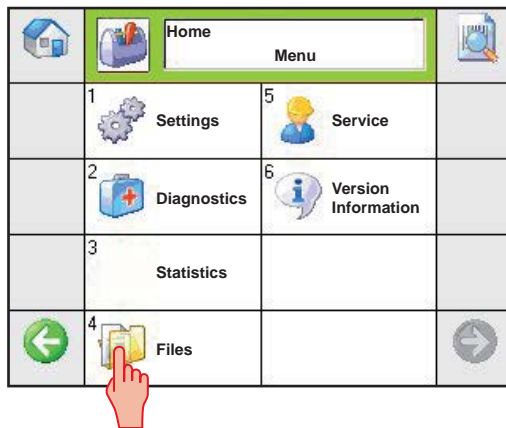

From the Menu screen select Files.

3

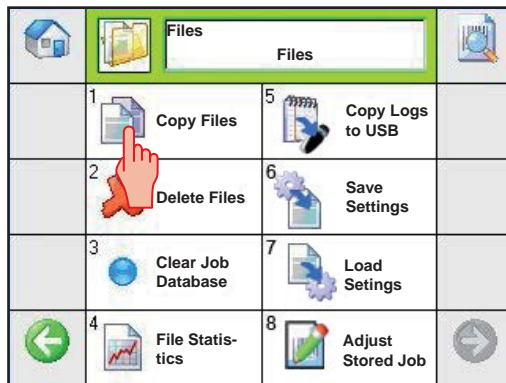

Select Copy Files.

4

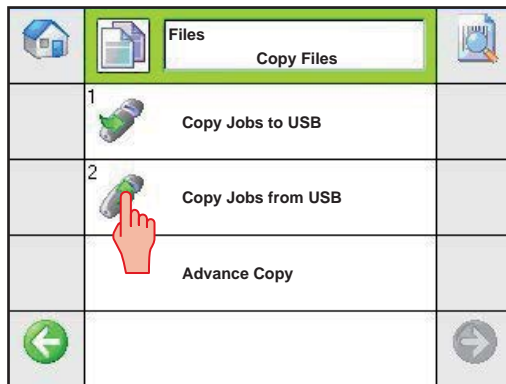

Select Copy Jobs from USB.

5

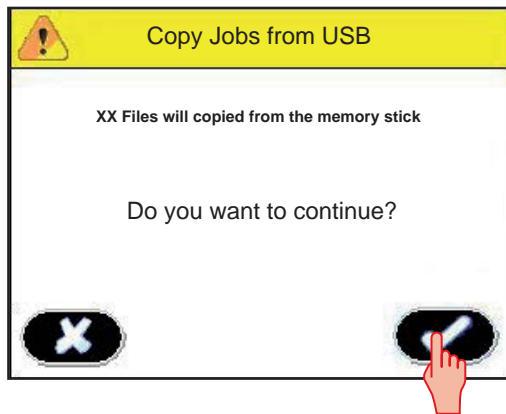

Select  to continue, the files will be copied to the printer database.

Description

■ Labels and Symbols

Serial/I.D./Rating Label



This label is located on the rear of the controller unit and indicates the following:

- CE mark
- Markem-Imaje corporation Logo
- Country of manufacture
- Machine type
- Patent information
- Electrical specifications
- Year of manufacture
- Serial number
- Fuse
- Cable connector labels

■ Beacon Light

The beacon light can be mounted in a fixed position on the production line.

The beacon has a three light system: Red, Orange and Green.

- When the red light is on, the SmartDate X60 has switched out of Run mode or there is a fault on the machine.
- When the Orange light is on, SmartDate X60 will still work normally, and warning messages are displayed, e.g. 'Low ribbon', etc.
- When the Green light is on, SmartDate X60 is ready to carry out the print process or is awaiting a signal to start printing.



Description

Interface



Interface



■ Introduction

This section describes how to operate the SmartDate X60 unit once it has been successfully installed.

Topics covered in this section include:

- The User Interface
- Keypad
- Icons
- Menu Icons
- Screen Types
- Menu Screens
- Warning and Problem Alert Screens
- Security Login Screens
- Data Entry Screens
- Date Entry Screens
- Setting Adjustment Screens
- Job Setup Screens
- Special Screens
- Speed Profiles



■ The User Interface Panel

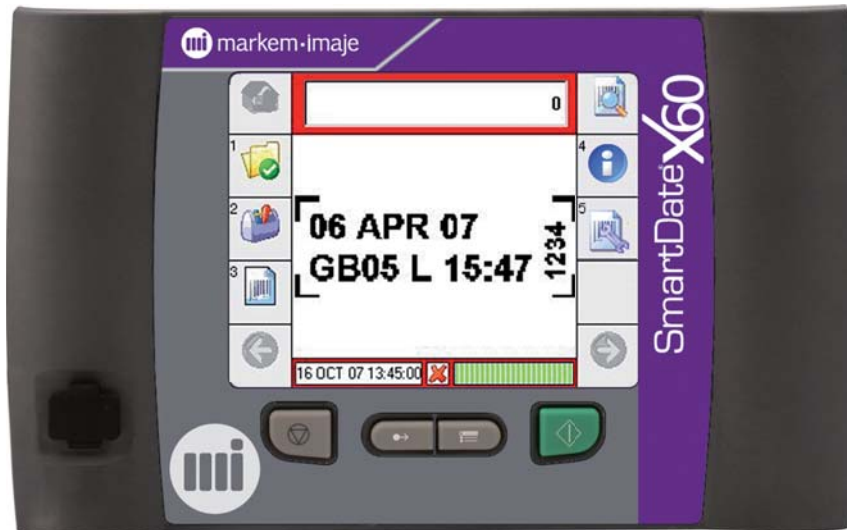

SmartDate X60 User Interface Screen

The user interface screen comprises of a LCD touchscreen and a four button hot key interface.

These four keys provide the following functionality:

- Starting the machine
- Stopping the machine
- Selecting a job
- Accessing the registration and offset functions.

In addition to this, a USB key slot intended for file transfers is also situated on the interface panel.

The screen can support graphics and text and the interface allows the user to access the SmartDate X60 menu structure.

The following options are available:

- Time and Date configuration
- Job selection.
- User Input data entry
- Printer Settings configuration.
- Diagnosis of the system Inputs and Outputs
- Statistical information about the printers performance.

▣ LCD Screen

The interface is composed of a 256-color, 320 x 240 pixel touch screen.

The screen supports graphics and Unicode characters.

Dependant on the printer function at the time, the screen will normally display with 5 or 6 touch buttons aligned down both the left and right sides of the screen and 3 larger areas in the centre of the screen.

The look of the screen will also vary dependant on the screen type being used.

Example of the Home screen layout:



Interface

■ Keypad

The Hot keys are positioned below the user interface screen, and consist of four rubber push buttons.



These keys allow you to start and stop the printer, select a job for printing and adjust the registration value.





















- 1- Stop producing
- 2- Registration
- 3- Select Job
- 4- Stop producing



■ Screen Icons

Icon	Name	Description
	Home	This option will return you to the Home screen.
	Print Preview	This option allows you to preview the selected job. The image can be enlarged or reduced in size and the details of each field can be viewed by using the Information button.
	Folder OK	This indicates that there are no faults or warnings active.
	Folder Warning	This indicates that there is one or more warnings active.
	Folder Fault	This indicates that there is one or more Fault messages active.
	Menus	This option allows you to access the menu options.
	Select job	This option allows you to select a job to be printed.
	Counts	This option allows you to view the various printer counts.
	Print Adjust	This option allows you to configure the basic print settings.
	Settings	This option allows access to the printer settings menus.
	Diagnostics	This option allows access to the various diagnostics functions.
	Information or Statistics	This option allows you to view the selected Image field information or statistical details about the printers performance. E.G. Software version or Language file version.
	Files	This option allows you to manage the various Database files.
	Service	This option allows access to the Service menu. This is password protected.
	Version Information	This option allows you to view specific information about the printer, such as the software version.
	Machine settings	This option allows you to configure the various printer settings.

Interface

	Display Settings	This option allows you to calibrate the Touch Screen.
	Adjust RTC	This option allows you to configure the Time and Date settings.
	Language	This option allows you to select the required language for the Touch Screen.
	Enable Security	This option allows you to Enable or Disable the Security function.
	FlexIO map	This option allows you to configure the Flexible I/O settings.
	Notepad	This option allows you to edit the setting of the selected feature.
	Data Input	This option allows you to use the Alphanumeric keypad function to enter data.
	Zoom in	This button allows you to enlarge the image size.
	Zoom out	This button allows you to reduce the image size.
	Navigate right	This button allows you to move to the next option to the right.
	Navigate left	This button allows you to move to the next option to the left.
	Page up	This button allows you to move down to the next page.
	Page down	This button allows you to move up to the previous page.
	Move up	This button allows you to move up to the previous selection.
	Move down	This button allows you to move down to the next selection.
	Navigate forward	This button allows you to move across to the next screen.
	Navigate back	This button allows you to move back to the previous screen.
	Check	This button indicates that you are satisfied with any changes you have made and wish to complete.

■ Screen Types

The SmartDate X60 User Interface supports various Screen Types. The screen is generally divided into a main central screen with option buttons down either side. The four corner buttons are used for navigation, returning to the Home screen or accessing the Print Preview.

Example:

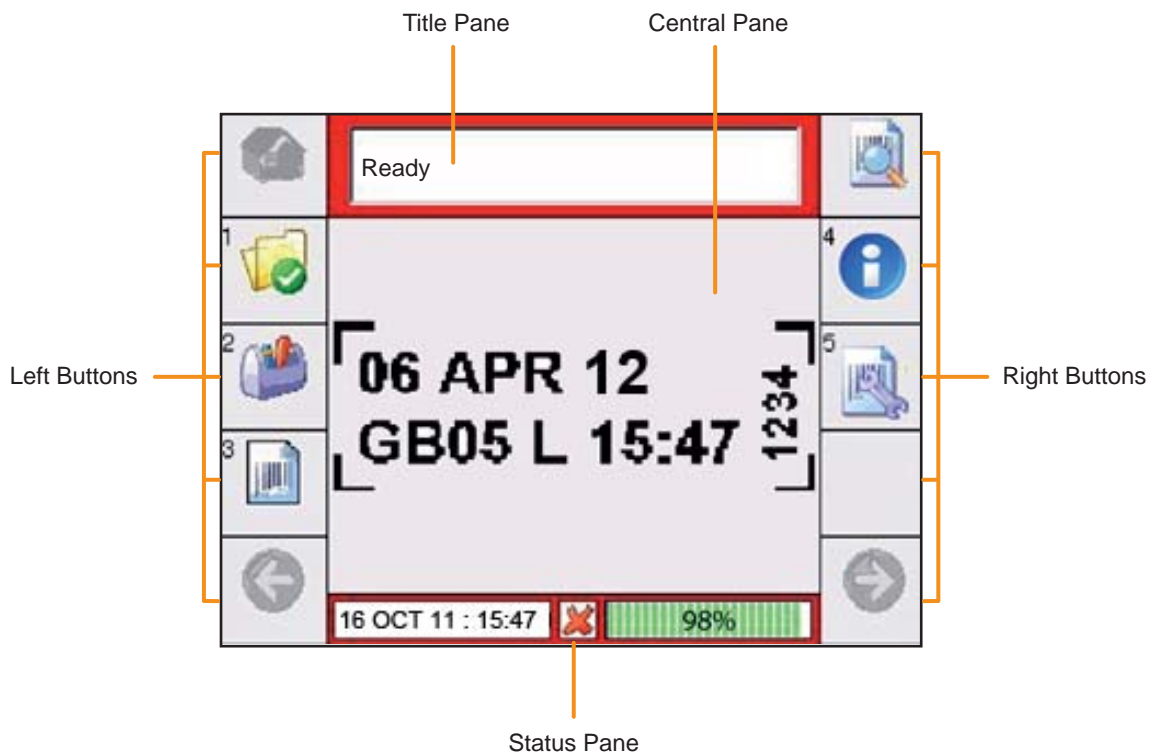

Interface

Example of Menu Screen Layout 1:

In this example the Menu options are displayed in the central screen area. Where four or less menu options are displayed the central screen is split into a title pane and four option panes. The four corner buttons are used for navigation, returning to the Home screen or accessing the Print Preview.

Example:

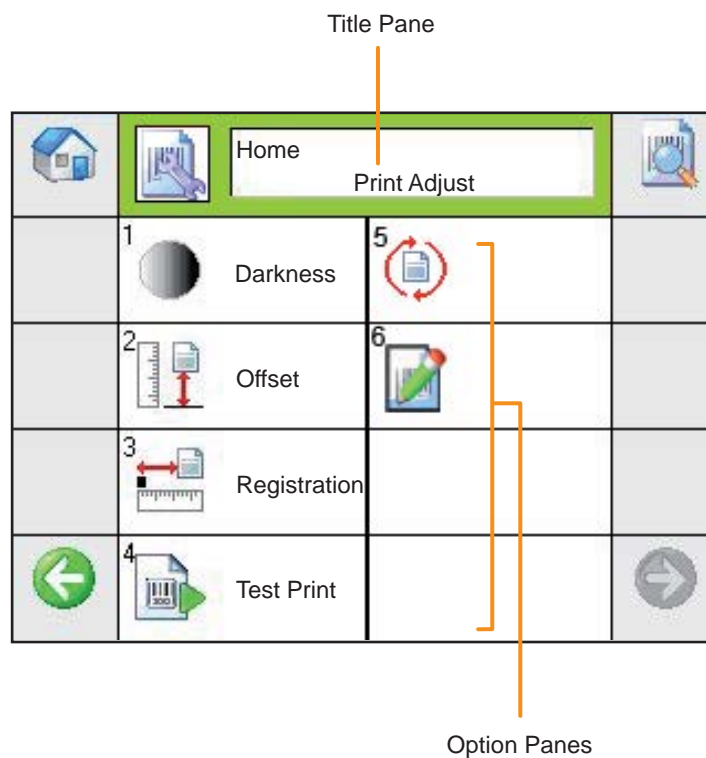

Example of Menu Screen Layout 2:

Where five or more menu options are displayed the central screen is split into a title pane and eight option panes. The four corner buttons are used for navigation, returning to the Home screen or accessing the Print Preview.

Example:

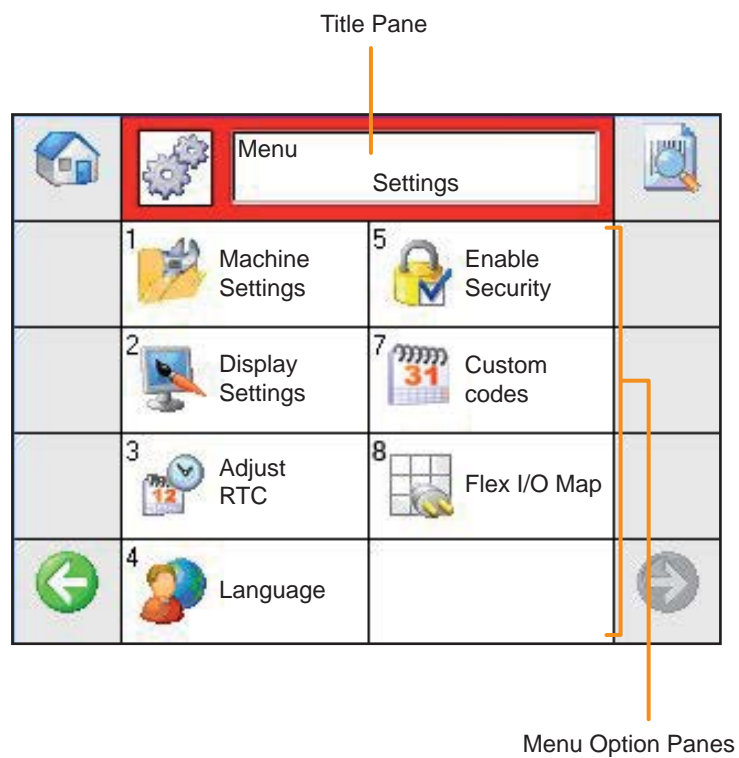

Interface

Example of Menu Screen Layout 3:

Where a large amount of detail has to be displayed, the central screen is further divided into a list of options.

You can then use the arrows to navigate up or down the list or move across the lists. The four corner buttons are used for navigation, returning to the Home screen or accessing the Print Preview.

Example:

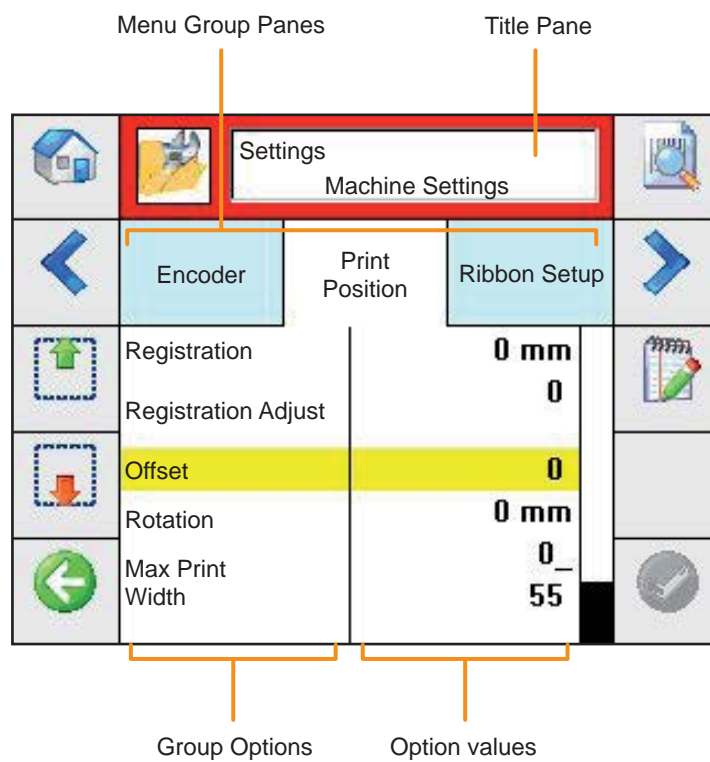

The screen types can be grouped as follows:

Screen Type	Description
Home Screen	The main screen from which the user starts
Menu Screens	Used to navigate between different menu options or screen types.
Data Entry Screens	Used to enter data for Job setup or printer settings.
Reports Screens	Used to display a large amount of textual information.
Diagnostic Screens	Used to display real time dynamic data.
Special Screens	Used to display special information such as Warnings or Problems.



Interface

■ Home Screen

The Home Screen is the main screen from which the user starts. This can either be the Ready Screen or the Producing Screen. The various menus can be accessed from both versions of this screen.

Ready Screen:

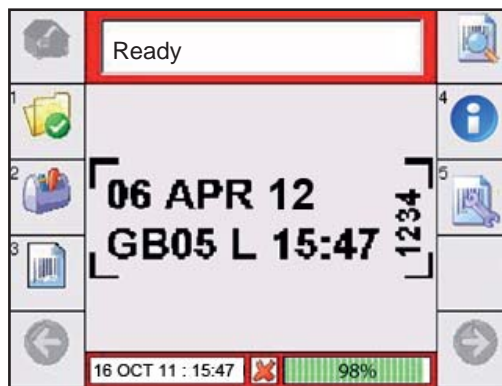

Producing Screen:

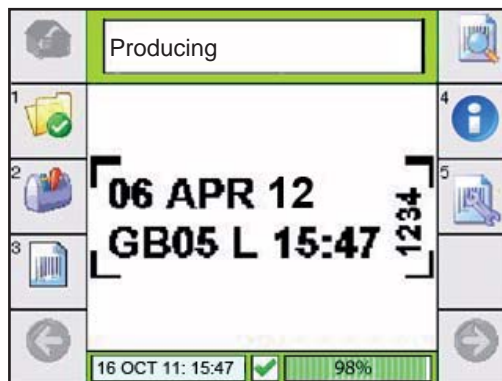

■ Security Login Screen

This screen is displayed whenever a password is required.

If you select one of the options you will then be prompted for a Login Password.

If the Security level has been enabled the menu screen will display the numerical password screen.

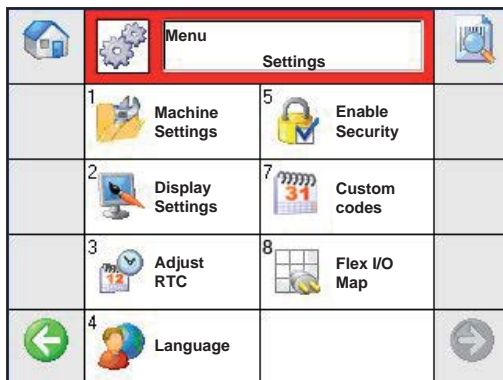
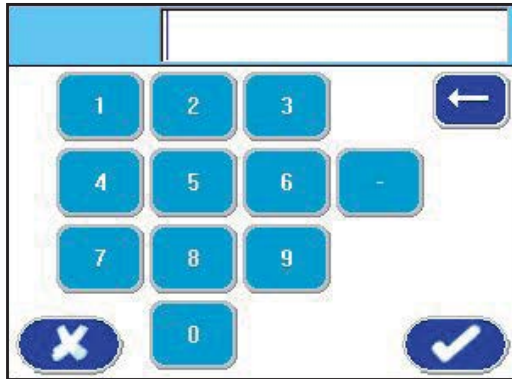

Different levels of access can be configured for different users.

Security settings are enabled or disabled from the Settings \ Machine Settings \ Security menu option.

Configuration of different passwords and access levels is done from CoLOS Control.

■ Security Options

SmartDate X60 can be configured to prompt for a password before access to the various menu options is allowed.

Two security level options are available to gain access to the menus.

- Open
- Medium

If the security setting is Open no password prompt will be displayed.

If the security setting is Medium you will be prompted for an access password.

SmartDate X60 is shipped with three default passwords, these are 1111, 2222 and 3333.

The different passwords allow different levels of access.

For example:

The default operator level password 1111 only allows access to Job selection and adjustment of the print darkness and print position.

The default supervisor level password 2222 only allows access to the options above and some additional features such as setting the SmartDate X60 default Date and Time.

The default Installation engineer level password 3333 allows access to all of the available menu options.

These passwords can be re-configured to allow more options or additional passwords can be added. This is done from Markem-Imaje CoLOS Control.

Please consult the relevant documentation for details.

■ Menu Screens

Menus are navigated by selecting the required option button.
 After entering a menu, the top item in the list will be highlighted.
 From this point you can only scroll down.
 You can scroll down through the menu topics by using the **Red** down arrow button.
 You can scroll up through the menu topics by using the **Green** up arrow button.



Where more options are available you can page down or up to the next or previous group by using the Blue chevron arrow buttons.

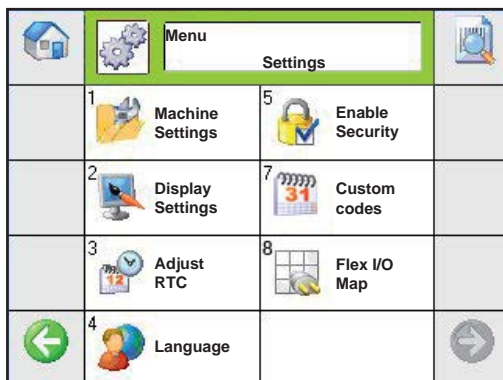

You can return to the previous screen by selecting the Green and White back arrow at the bottom left of the screen.

■ Data Entry Screens

Data entry screens will vary dependant on the menu option that has been selected.

These screens can be grouped as follows:

- Prompted Data Entry Screens
- Date Entry Screens
- Settings Adjustment Screens
- Job Setup Screens

■ Prompted Data

Prompted data entry screens collect input from the user as a result of Job designs that requires variable data to be entered during the Job selection process.

Because the Job design can prompt for different types of input, the screen types vary.



▣ Alpha Data Entry Screens

From this screen alpha data can be entered.



Once alpha characters have been entered, the screen cursor can be moved to individual characters by using the arrows to the left and right of the input pane.

Individual characters can be deleted by using the back arrow button on the right of the screen.

When the data entry is complete select the Tick symbol at the bottom right of the screen.

▣ Numeric Data Entry Screens

From this screen numeric data can be entered.

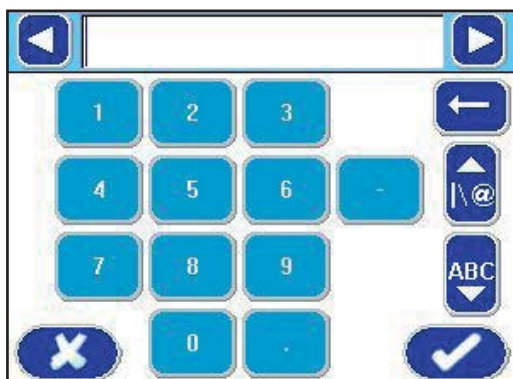

Once numbers have been entered, the screen cursor can be moved to individual numbers by using the arrows to the left and right of the input pane.

Individual numbers can be deleted by using the back arrow button on the right of the screen.

Interface

- Language specific characters and symbols

From this screen language specific characters or symbols can be entered.



Display the appropriate option by using the two buttons on the right of the screen.

Once data has been entered, the screen cursor can be moved to individual characters or symbols by using the arrows to the left and right of the input pane.

Individual characters can be deleted by using the back arrow button on the right of the screen.

When the data entry is complete select the Tick button at the bottom right of the screen.

■ Date Entry Screens

There are three types of “Date Entry” screens that the User Interface has to support:

- Literal Date Entry
- Fixed Format Prompted Date Entry
- Offset Date Entry

▣ Literal Date Entry

This screen is used to prompt the setting of a fixed date to be printed. There is no calculation made on this date, it is displayed (Prompted) in the format that it will be printed. This means that the fields that make up the date string, can appear in any order, depending on how it was set at the design stage.

Select Job
Literal Date 1

[1 / 5]

31 10

Print Preview : 31 10

If required use the Blue + and - buttons to change the date before printing. Alternatively use the Calendar function to alter the date.

Select Job
Literal Date 2

[2 / 5]

31 - Oct - 2007

Print Preview : 31 10 07

Interface

▣ Fixed Format Date Entry

This screen is used to set a literal date to be printed, but this time the date is displayed in a fixed format. An example of where this option may be used is where the product is destined for another country. The user can set the date in their native language, and the preview will display how it will be printed in the other language.

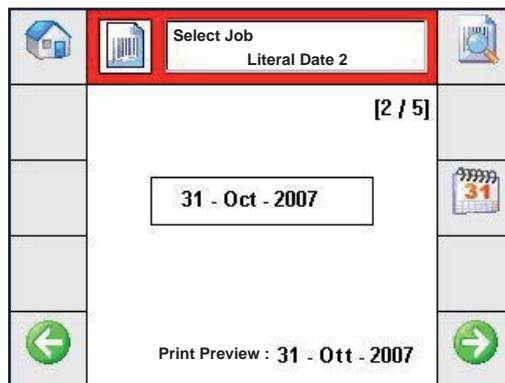

▣ Calendar



▣ Offset Date Entry

This screen is used to set an offset from the SmartDate X60 internal clock and to preview what the resultant date would be.

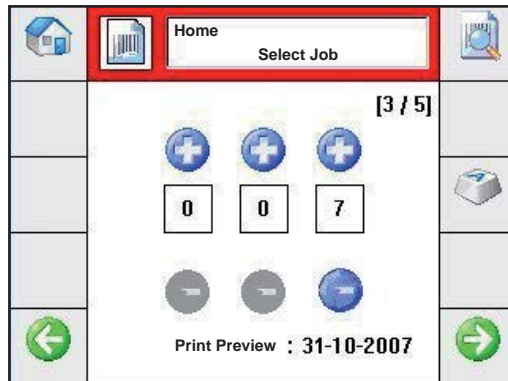

This example shows an offset of seven days, so the actual date that the SmartDate X60 internal clock is set to is the 24th October 2007.

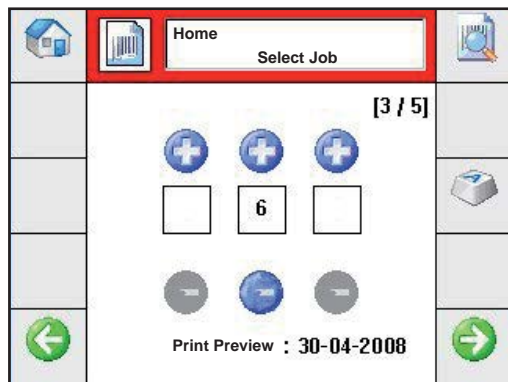

This example shows an offset of 6 months.

■ Diagnostics Screens

The Diagnostics screen displays the current status and dynamically changing data which give an aid to troubleshooting.

The information is read only and can therefore not be altered.

This screen allows access to the following information:

- Printer configuration
- Inputs status
- Outputs status
- Temperatures
- Print timings
- Internal Sensor status



■ Reports Screens

These screens are available under the **i** menu and give full details of what is expressed in abbreviated form on the Home page.

This includes full information about Warnings and Problems.

Information such the Software version number, Hardware serial numbers etc. Are displayed here. The information is static unlike the Diagnostics screens which display real time status details.

This screen allows access to the following information:

- Full details of Problems and Warnings.
- Current Job details.
- Details of the current Printer settings.
- Details of the Counts.
- Printer Version Information.



■ Special Screens

There are a number of special screens that may occasionally appear. Examples of these may be if a print can not be completed or if a new type of ribbon is loaded.

▣ Ribbon Type Verification

If SmartDate X60 detects that a new ribbon is loaded, it needs to confirm that the ribbon type is the same as the last type used. You will be prompted to confirm this or input the relevant data for the new ribbon type.





New Ribbon Setup	
Ribbon Grade	MARKEM 3810
Ribbon Width	30mm
Ribbon Color	Black

If you select NO you will then be prompted for the required information about the new ribbon type.



Wizard New Ribbon Setup	
↑	MARKEM 3100
	MARKEM 3410
↓	MARKEM 3510
	MARKEM 3710
	MARKEM 3810
←	MARKEM 3910
	MARKEM 4820

Select the correct ribbon type and press  to display the next option screen. When all options are complete press  to confirm.

▣ Faults and Warnings Alert Screens

These screens inform you of problems or potential problems. A description of the problem will be displayed on the screen.

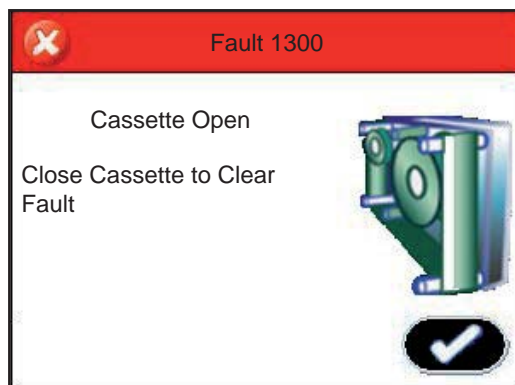

In the case of a Warning the SmartDate X60 will continue printing if in Producing mode. The Warning does not stop the print cycle.

An example of a **Warning** might be "Low Ribbon"

If a **Fault** occurs the SmartDate X60 will stop printing if in Producing mode and the Fault Alert screen will appear.



Interface

❑ Failed Prints

With Continuous printers there may be occasions where SmartDate X60 can not complete a print because the production speed slows to a point where printing can not take place.

If this happens you will be prompted with the option to manually discard the print or wait until the production speeds up again.

The action taken if the print is not discarded will depend on the **Low Speed Print Mode** setup.

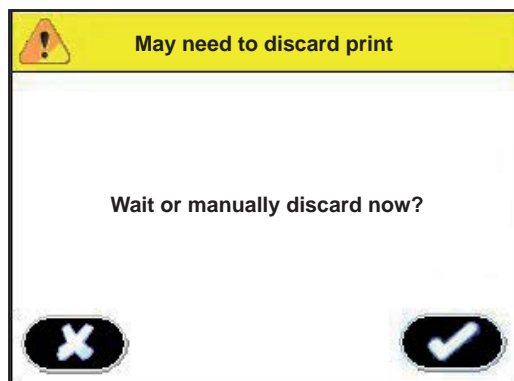

It is important to note that this is an option and that waiting may correct the warning.

▣ Dead Dot Detection

SmartDate X60 will automatically detect if any of the printhead dots have been damaged.

A warning icon will be displayed in the Status box on the upper left hand side of the screen.

1

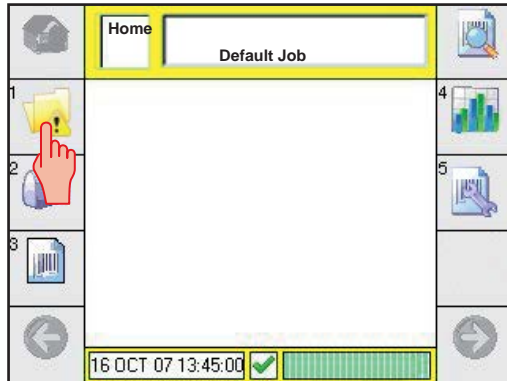

Selecting this icon will display the warning message

2

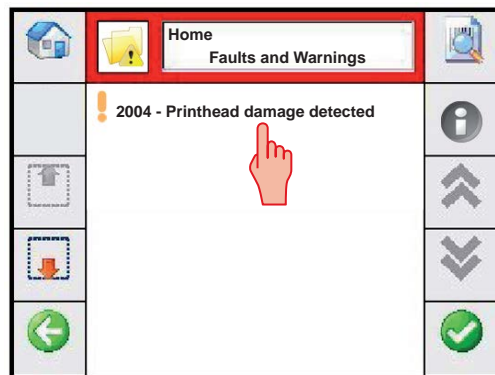

Select the warning message and then press 

3



The printhead damage details are displayed.

■ Power saved mode

If activated the printer will revert to power saved mode after 2min, 30min, 2h, or 6h as selected.



Operation



Operation



■ Introduction

This section describes how to operate the SmartDate X60 unit once it has been successfully installed.

Topics covered in this section include:

- Starting the SmartDate X60
- Stopping the SmartDate X60
- Print Adjustment screens
- Changing the Ribbon
- Principles of printing
- Operating principles
- Operating modes



Operation

■ Start the printer

▣ Home Screen

The Home Screen is the main screen from which the user starts. This can either be the Stopped Screen or the Run Screen. The various menus can be accessed from both versions of this screen.

Ready Screen:

1

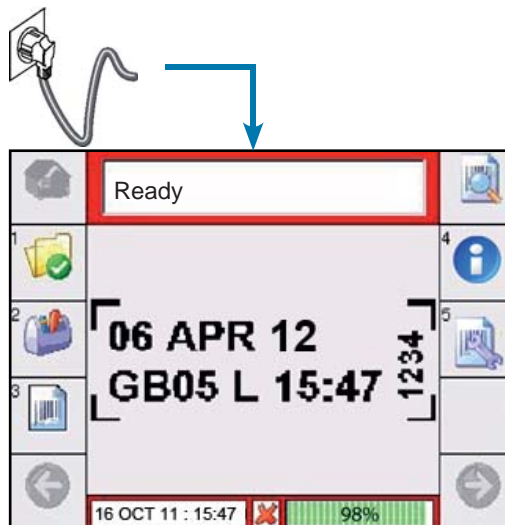

To start the printer press the right hand button. This will put the SmartDate X60 into "Producing" mode.

2



Printing will only occur when the Host machine is in producing mode and a relative print signal is received.

■ Stop the printer

Producing Screen

1

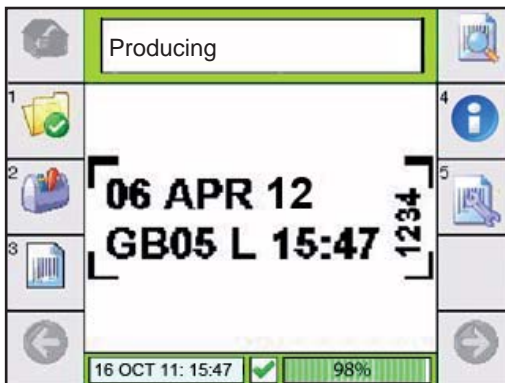

To stop the printer press the right hand button .
This will put the printer into “Ready” mode and the SmartDate X60 will ignore any print signals form the Host machine.

2

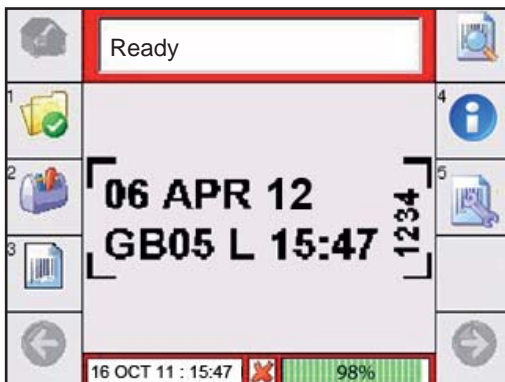

■ Information

The Information Screen provides details about the performance of the SmartDate X60.

	 Home Information	
1	 Counts	5  Job History
2	 Supplies	
3	 Health	
	4  Printhead Information	

▣ Counts

This screen displays the current status of the printer counters.

Home		Counts	
Batch Good	0		
Batch Spoiled	0		
Batch Missed	0		
Batch Discarded	0	↑	
Batch Low Speed	0		
Batch Failed	0	↓	
Total Good	0		
Total Spoiled	0		
Total Missed	0		

Batch Good Counts	This is the number of successful prints with current selected image
Batch Spoiled Counts	This is printed image with part of the image missing e.g. A field that is off the image.
Batch Missed Count	This is the number of print signals received that could not be actioned.
Batch Discarded Count	This is the number of prints that have been discarded either manually or automatically because of low speed.
Batch Low Speed Count	This is the number of prints that have been achieved at low print speeds.
Batch Failed Count	This is the number of prints that failed because of the above reasons.
Total Good Counts	This is the total number of successful prints.
Total Spoiled Counts	This is the total number of spoiled prints.
Total Missed Count	This is the total number of missed prints.
Total Discarded Count	This is the total number of discarded prints.
Total Low Speed Count	This is the total number of Low speed prints.
Total Failed Count	This is the total number of failed prints.

Operation

▣ Supplies

The Supplies Screen provides information about the available ribbon and number of prints that can be completed before a ribbon change is required.

When the printer is in producing mode the remaining time will also be displayed with respect to the current print cycle time.

The Supplies Screen



The Supplies monitoring screen can be accessed from either the Home screen, by pressing the supplies bar or from the Diagnostics menu.

The following information can be viewed:

Percentage Ribbon Remaining

This figure shows the percentage amount of ribbon left on the supply reel. The value is calculated and updated approximately every one hundred prints.

Remaining Prints on Ribbon

This is calculated as the number of prints that can be completed with the existing ribbon prior to requiring replacement. This calculation is based on the assumption that the current job settings and rate of production are held constant.

Remaining Time

This figure shows the amount of time left until the ribbon runs out. The calculation of this figure is based on the assumption that production continues at the current pack rate, with the same length of image and settings values affecting the ribbon usage.

This time is calculated and updated every ten seconds.

▣ Health

The Health screen displays metrics relating to the operational efficiency of your installation. In order to compute these metrics the SmartDate distinguishes between and measures, the time spent in different states.

Uptime is the duration for which the SmartDate is available and ready to print if configured to do so. Uptime accumulates when the SmartDate is fault free. This includes time spent powered off with no faults.

Downtime is the duration for which the SmartDate is unavailable due to an operational fault, not related to ribbon change. Downtime includes the time spent switched off with this fault.

Ribbon Change Time is the duration for which the SmartDate is not able to print due to the ribbon being replaced. Ribbon time starts accumulating as soon as the (1208 - End of Ribbon fault) or (1212 - Low Ribbon Detected) is detected. It stops increasing once the system has re-entered the READY state.



Operation

Two machine efficiency measures are derived from these times:

% Availability measures % uptime achieved by the system having excluded Ribbon Change Time from the calculation.

$$\text{\% Availability} = \text{Uptime} / (\text{Uptime} + \text{Downtime})$$

This gives a good overall measure of the SmartDate's health. A low availability metric implies a configuration issue that is compromising the amount of time you can successfully use the machine.

% Uptime measures the uptime efficiency achieved by the system and includes Ribbon Change Time in the calculation.

$$\text{\% Uptime} = \text{Uptime} / (\text{Uptime} + \text{Downtime} + \text{Ribbon Change Time})$$

This gives a good overall measure of the operational efficiency achieved by the system taking into account routine maintenance. A low metric implies that operational efficiency may be improved by (eg) using longer ribbon, better planning of ribbon replacement times etc.

Both of these metrics are calculated over two different time periods.

Lifetime metrics are measured from the time the firmware was installed or the system restored to the factory setup.

Daily metrics are measured from either midnight or when the printer was last power cycled - which ever happened last.



■ The Health Screen

The Health screen displays four distinct metrics calculated from above.

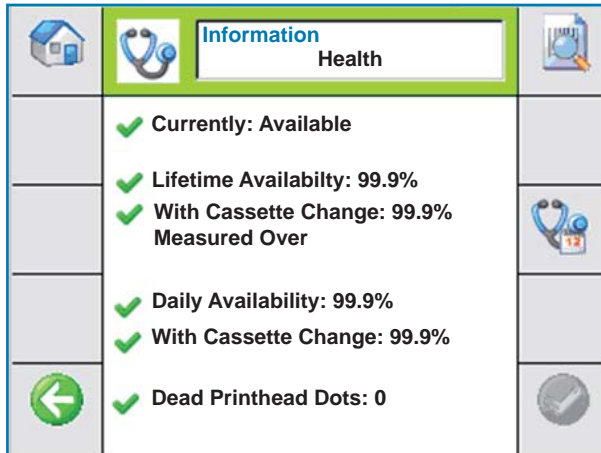

Information		Health	
✓	Currently: Available		
✓	Lifetime Availability: 99.9%		
✓	With Cassette Change: 99.9%	✓	12
✓	Daily Availability: 99.9%		
✓	With Cassette Change: 99.9%		
✓	Dead Printhead Dots: 0	✓	

Also displayed is the :

Current state of the machine - either **Available**, **Changing Ribbon** or **In Fault**.

The duration over which the lifetime metrics have been calculated.

The number of damaged printhead dots.

Each metric is associated with an Icon indicating whether the metric is acceptable (a tick) or a potential problem (a warning sign)

Availability metrics are ticked if they are above 99.5%

Uptime metrics are ticked if they are above 90%

Printhead dot damage is ticked if the value is 0

Operation

■ The Availability Log Screen

The SmartDate X60 provides an additional screen to help determine what is affecting the metrics reported. It displays up to 100 events that may lead to reduced uptime.

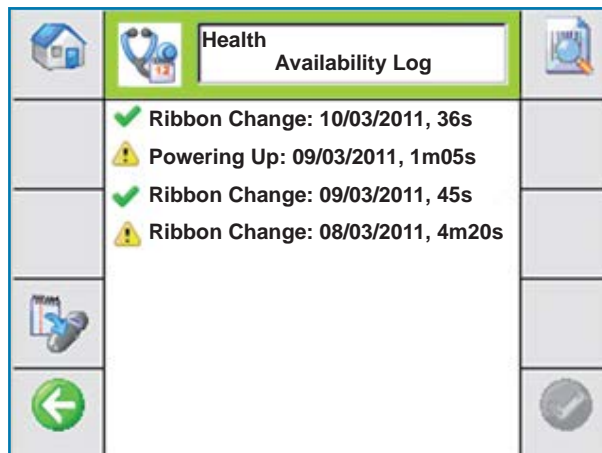

This type of event is recorded along with the date it occurred (dd/mm/yyyy) and the duration (days, hours, minutes and seconds). Events affecting the availability have a warning icon, alternatively events affecting the uptime alone are ticked.

The screen contains a button to save the availability log to a USB stick as the file availability.log This saves all of the events recorded in the availability log(opposed to the 100 displayed on the screen) as a comma separated value file.

■ The Printhead Information Screen

The printhead Information Screen displays details of information stored in Markem-Imaje Smart-chip thermal transfer printheads. This includes details of the printhead's identity, usage and printhead dot check health. This screen also provides the option to save this information to a Printhead Data Log file.

Information Printhead information	
Identity	Usage
Serial #	00-00000
Type	Kyocera BH 53mm
Manufacture Date	23/3/2010
Manufacture ID	000
Initial Printer Serial #	00 00000000 AB
Initial Printer Date	23/03/2010
Final Printer Serial #	000000 00000000 AD
Final Printer Date	01/03/2011

Operation

▣ Identity

This screen allows you to view information with regard to serial numbers, model numbers and dates of printhead changes.

Identity	Description	
Serial Number	New printhead serial number	Written once at manufacture
Type	Numeric model number	Written once at manufacture
Manufacture Date	Date of manufacture	Written once at manufacture
Manufacture ID	Numeric ID of manufacturer	Written once at manufacture
Initial Printer Serial Number	Serial number of the first printer within which the printhead was fitted	Written once at fitting
Initial Printer Date	Date at which the printhead was first fitted to the printer	Written once at fitting
Final Printer Serial Number#	Last known printer to which the printhead was fitted	Updated when fitted in a different printer
Final Printer Date	Date at which the printhead was first fitted in the final printer	Updated when fitted in a different printer



▣ Usage

This screen allows you to view information with regard to the performance of the printer.

Usage	Description
Print Count	Number of print cycles performed
Ribbon KM	Amount of ribbon fed past the printhead
Direct Thermal KM	Amount of substrate fed past the printhead
Darkness	Last known printhead darkness setting value used to print
Print Speed	Maximum darkness value used to print
Maximum Print Speed	Last known print speed averaged over one hour of production
Minimum Ribbon Width	Minimum ribbon width fitted while printing
Temperature	Last known temperature while printing
Maximum Temperature	Maximum temperature value recorded while printing

▣ Dot Check History

If a printhead dot (resistor) is damaged the Smartdate will record the printhead width and the date that any new printhead damage occurred. This data can be recorded to a Log file if required.

▣ Firmware History

This screen displays the date of any firmware changes that have taken place.

Operation

■ Job History

The Job History screen provides information about changes to the work history of the SmartDate X60. This includes the Date and Time of any new job selected.

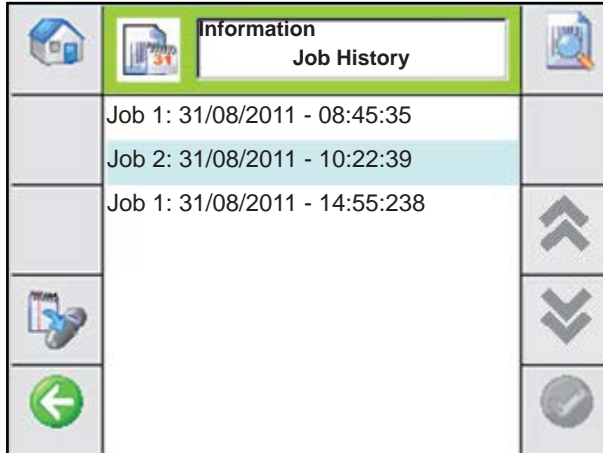

Information	
Job History	
Job 1: 31/08/2011 - 08:45:35	
Job 2: 31/08/2011 - 10:22:39	
Job 1: 31/08/2011 - 14:55:238	

■ Print Adjust Screen

This screen allows you to configure the print settings for the SmartDate X60. Five options are available for adjustment plus the Test Print function.

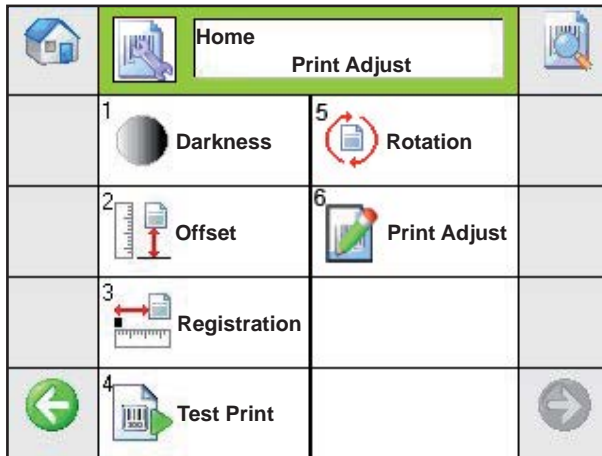

▣ Print Darkness

The print darkness menu allows you to adjust the amount of energy used by the printhead. This will effectively change the contrast of the print on the substrate.

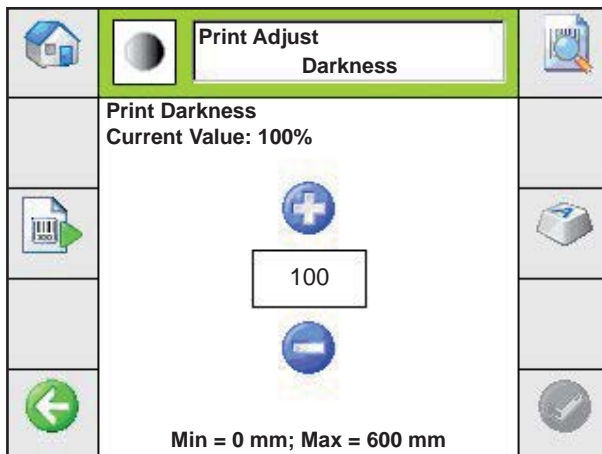

Operation

▣ Offset

This is the position of the print relative to the Printhead.

Increasing the offset will move the position of the print across the printhead.

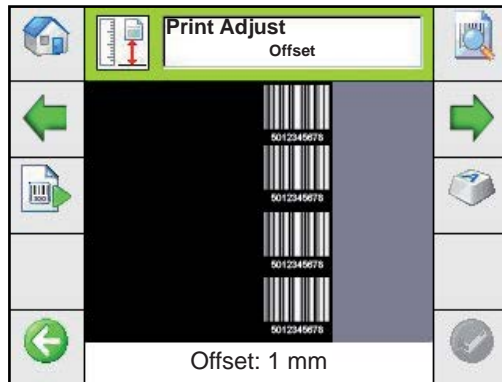

The black background represents the ribbon width.

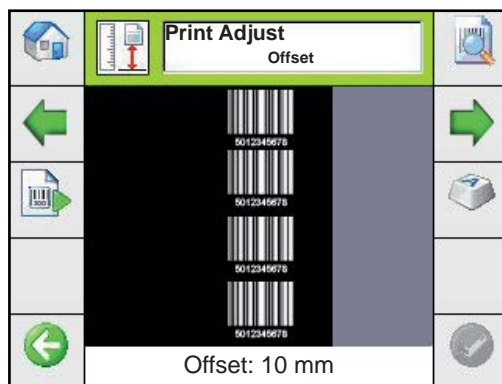

▣ Registration

This is the position of the print relative to the direction of the substrate. Increasing the registration will move the position of the print further back on the substrate.

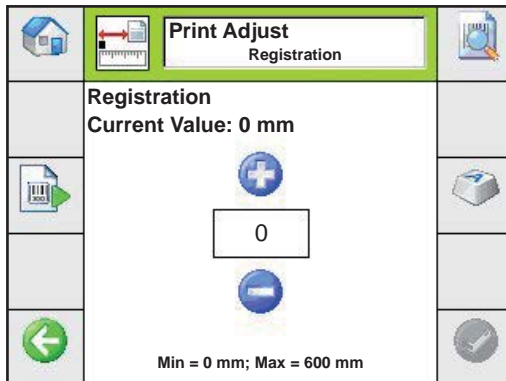

▣ Test Print of the Current Job

This option allows you to activate a test print of the current selected job. To access the Test Print option:

From the Menu screen select Test Print.

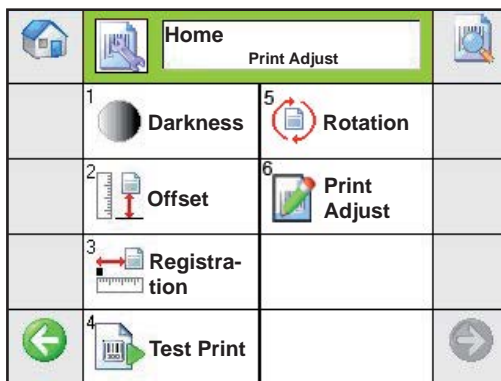

If the machine type is an Intermittent printer the print will be activated immediately. If the machine type is a continuous printer the target material must be in motion for the action to take place.

Operation

▣ Rotation

This screen allows you to rotate the selected image by 180o

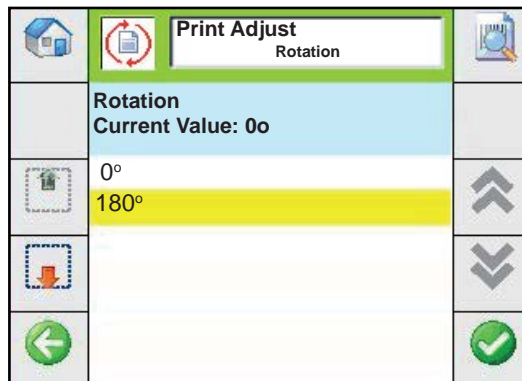

▣ Adjust Image

This screen allows you to adjust the position of specific fields on the image being printed.

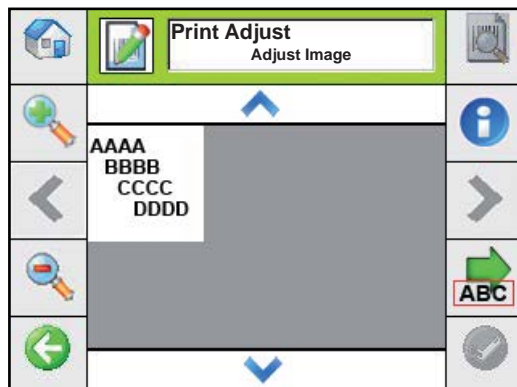

Increase the Image size to enable a better view of the image if required.

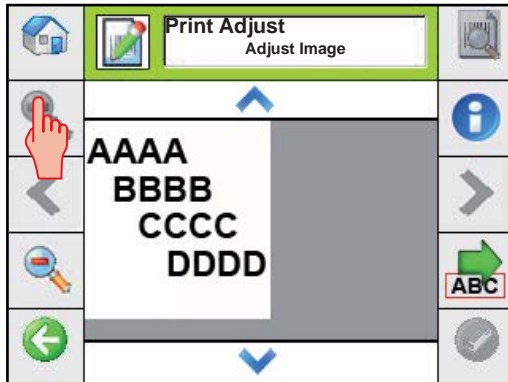

Select the field that requires moving.

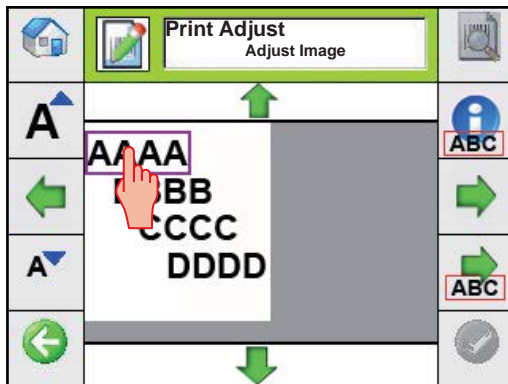

Use the Arrow keys to move the field to the required position.

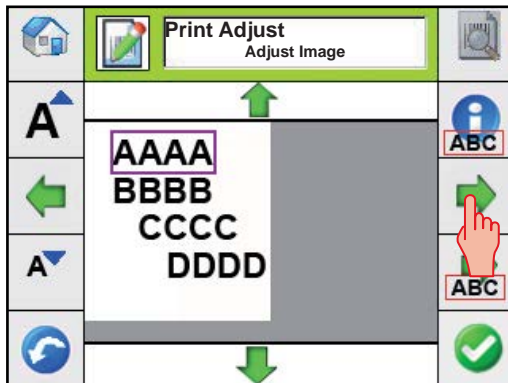

Use the "A" icons to Increase or decrease the size of the font if required.

■ Removing the cassette

1



Rotate the locking lever on the cassette to the OPEN position.

2



Use the handle to withdraw the cassette.

3

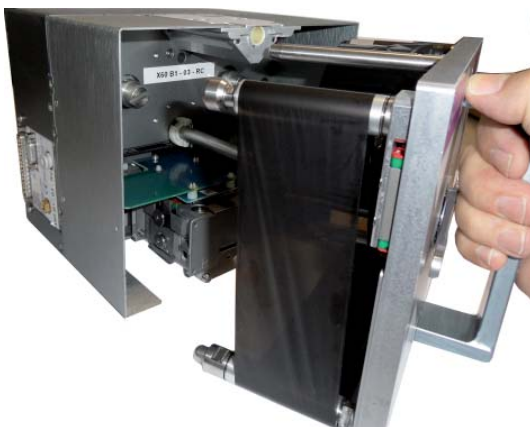

Remove the waste ribbon from the cassette.

■ Loading or Replacing the Ribbon

- ▣ Removing Waste Ribbon from the Waste Take up Core

1

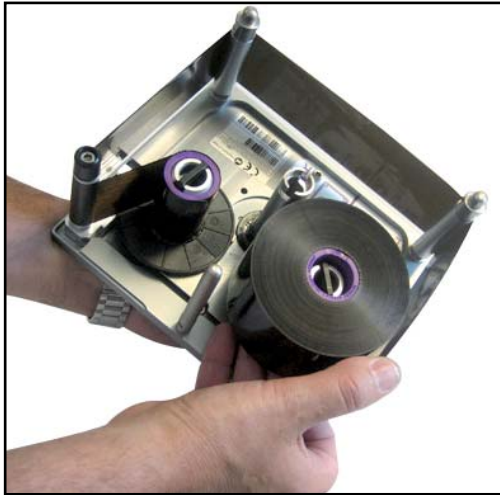

Pull the ribbon forward using the ribbon take up reel flange located below the ribbon.

2

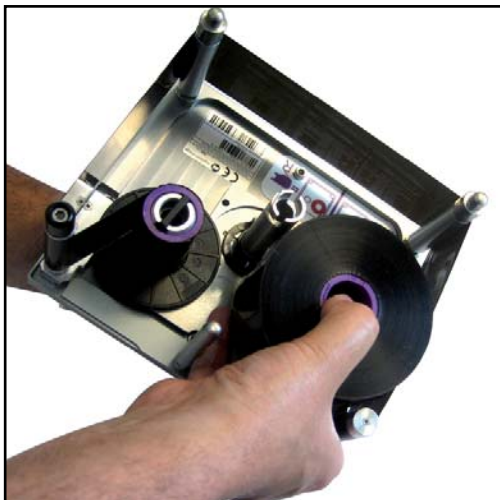

Push the flange back to its original position.
Pull off the ribbon by hand.

Do not use sharp objects such as screwdrivers to remove the ribbon as this may cause injury.

■ Loading a New Ribbon

- 1 Fit a new waste take up core and load a new ribbon following the web pattern shown inside the cassette. (New ribbon on the red reel)
- 2 Remove sufficient ribbon from the new roll to make it unnecessary to pull additional ribbon while the cassette is partially loaded. This makes loading easier and, in extreme cases, prevents damage to the printer cassette.
- 3 Ensure that there are no creases in the ribbon by rotating the take up reel by hand.
- 4 Ensure that the ribbon is tracking parallel on the cassette rollers and is positioned correctly. The ribbon must be loaded so that it is only in contact with the movable parts of the rollers.
- 5 Ensure that the ribbon is wound forward enough so that the transparent lead section is not under the printhead.



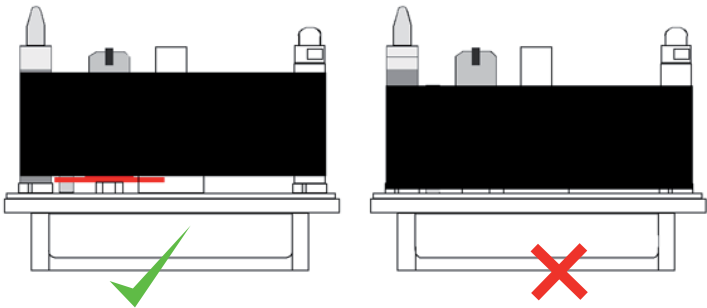

Full width ribbon.

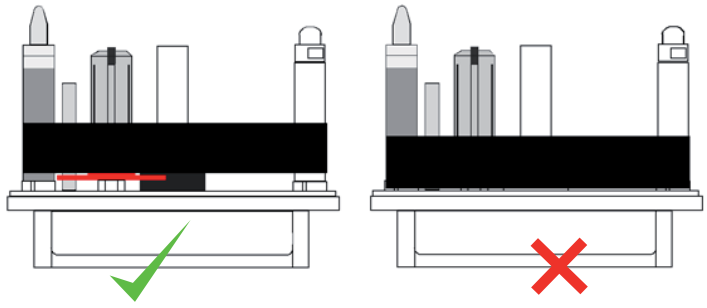

Narrow ribbon.

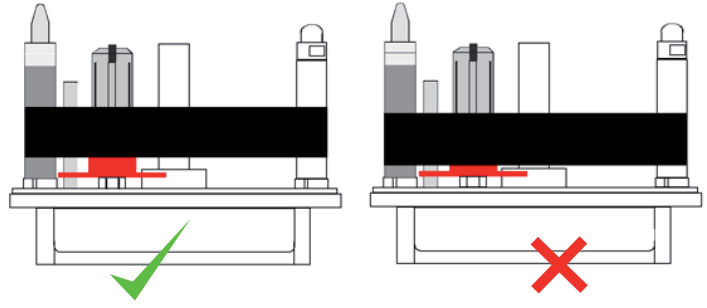

Narrow ribbon with spacer.

Operation

■ Re- Connecting a Broken Ribbon

If a ribbon break occurs the following procedure should be used:

- 1 Do not tie a knot to re-connect the ribbon.
- 2 Wind the remaining waste ribbon onto the waste core.
- 3 Pull some of the unused ribbon from the ribbon supply and wind it onto the waste ribbon take up.
- 4 Turn the waste reel by hand at least one revolution and keep the join between the two as flat as possible.

Failure to follow this procedure may cause unacceptable eccentricity on the waste ribbon take up reel. This cannot be controlled by the printer and will produce ribbon tension problems.

▣ Cassette Webbing Diagrams

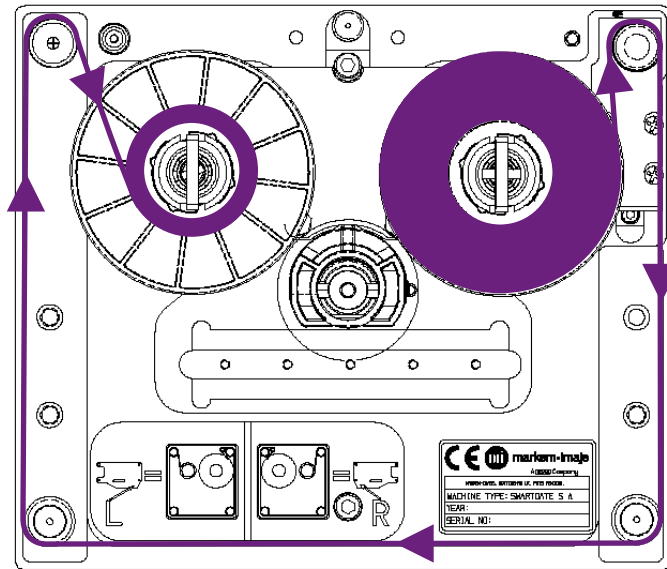

SmartDate X60 LH Cassette Ribbon Web Path

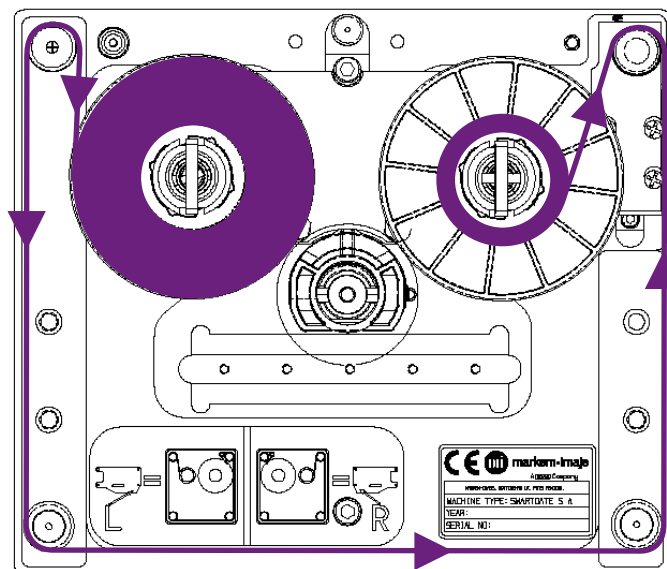

SmartDate X60 RH Cassette Ribbon Web Path RH

Operation

▣ Replacing the Cassette

- 1 Check that the cassette locking lever is in the **OPEN** position. Insert the printer cassette by aligning the two guide pins (see the appropriate webbing diagram) and pressing the unit home.
- 2 Check that the ribbon passes over the peel bar correctly.
- 3 Lock the unit shut by turning the locking lever to the **CLOSED** position.
- 4 When the cassette is back in position and the printer is set to **READY**, SmartDate X60 automatically drives the head to remove any creases and to calibrate the ribbon feed sensor.
- 5 If the message **CALIBRATION FAILED** is displayed, remove the cassette.
- 6 Check that the ribbon is threaded correctly and try again.

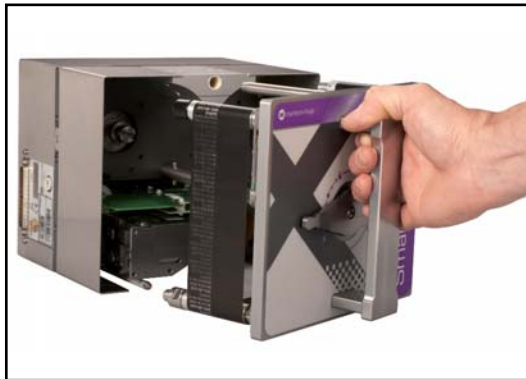

■ Principles of Printing

▣ Thermal Transfer Technology

SmartDate X60 machines use Thermal Transfer printheads, similar to the ones used in Fax machines.

Thermal Transfer printers can also operate without ribbon by using specially treated paper which turns black when heated. This is the way fax paper reacts.

Overprinters however, almost always use ribbon.

Both SmartDate X60 machines use Thermal transfer printheads for printing.

Each printhead has a series of heating elements (resistors) along the print line. These printing dots are 12 per mm and are covered in a ceramic glaze for protection.

When printing, the printhead is moved out by activating a pneumatic cylinder. This causes the printhead to press the ink ribbon against the substrate or label. The heat from the printhead dots melt the ink and the pressure of the printhead against the substrate transfers the ink to the substrate.

SmartDate X60 machines use Stepper Motors for Printhead motion and Ribbon feed.



Operation

▣ Print Process

With the **Intermittent** printers, the step rate of the printhead carriage motor is in direct relationship with the linear motion of the carriage.

The length of time that the dots are energised for is determined by the linear speed of the printhead carriage.

With the **Continuous** motion versions of the printer, the length of time that the dots are energised is determined by the speed of the ribbon, which in turn is controlled by data from a speed encoder.

The print control processor determines which dots to energise and when to activate them.

In both cases the length of each dot should end up at 1/12 mm to maintain the aspect ratio of the character being printed.

An example of how this works is shown below:

If an **Intermittent** printer were to print the following sequence:

- Dots 1 to 12 are energised three times relative to the linear speed of the print carriage.
- Dots 4 to 8 are energised eighteen times relative to the linear speed of the print carriage.
- Dots 1 to 12 are again energised three times relative to the linear speed of the print carriage.

If a **Continuous** printer were to energise the dots in this sequence it would be relative to the ribbon speed.

In both cases the printed image would then look as follows:

The resulting character may then be part of the design text or a part of a Graphic or a Logo. This process happens extremely fast and the printed character may only take a fraction of a second to print.

For example:

The above character is represented as 26 steps long, just over 2 mm. If the print speed were 100 mm/sec, this character would only take approximately 2/100 of a second to print.

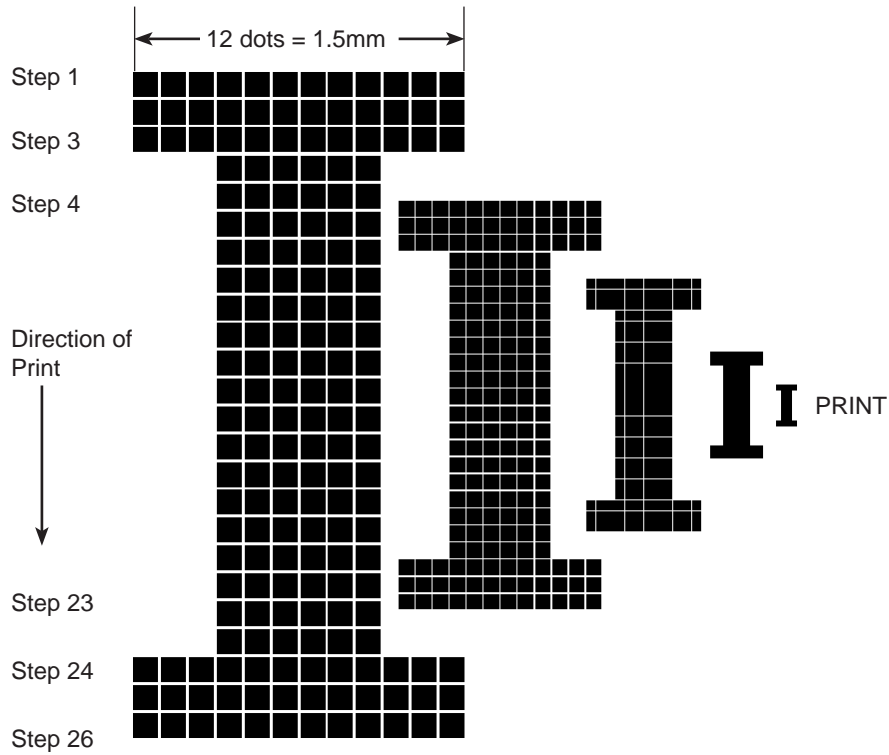

■ Operating Principles

The two printer types use different methods of operation specifically designed to suit the running methods of the packaging machines being used.

When the cassette is inserted into the printer body and secured, the ribbon supply shaft and ribbon waste rewind shaft, are connected to the ribbon drive motor couplings.

The SmartDate X60 Intermittent printer uses a thermal printhead and thermal ink ribbon to print information onto materials held against a flat Print platen.

The SmartDate X60 Continuous printer uses a thermal printhead and thermal ink ribbon to print information onto materials held against a Print roller.



■ Print Cycle SmartDate X60 - Intermittent Printer

The SmartDate X60 in this mode has a print area of 53mm x 75mm and print speeds of 70 to 700mm/s.

The SmartDate X60 Intermittent prints when the substrate or label is stationary.

The printhead is moved out during the dwell time of the packaging /labelling machine, and then moved across the substrate / label while printing takes place.

The Intermittent model advances the ribbon during the return movement of the printhead. The ribbon is only advanced by the same amount as it prints.

For example, if the image is 25mm long, the ribbon is advanced by 25 mm (plus any gap between prints). This keeps ribbon waste to a minimum.

The SmartDate X60 Intermittent prints text and bar codes at any position within the 53mm width by 75mm length print area.

The operating sequence is:

A Print Go signal triggers the print delay timer.

The print delay elapses and the printhead moves into position.

The printhead moves along a linear slide and prints the required information.

The printhead retracts.

The printhead returns to its home position and the ribbon moves along ready for the next print.

SmartDate X60 is now ready for the next print sequence.



Operation

■ Print Cycle SmartDate X60 - Continuous Mode Printer

The SmartDate X60 in this mode has a print area of 53 mm x 150 mm and print speeds of 30 to 1000 mm/s.

The SmartDate X60 Continuous prints while the substrate is moving.

In this case the printhead only moves out to the print position and has no linear motion. A shaft encoder is used to track the substrate speed.

The ribbon speed is accelerated up to match the substrate speed before printing can occur. This is done by means of two stepper motors.

The SmartDate X60 Continuous prints text and bar codes at any position within the 53mm width by 150 mm length print area.

This makes it the ideal coder for continuous motion form fill and seal machines and horizontal flow wrappers, where larger images are required and fast print speeds are not an issue.

The operating sequence is:

1. A Print Go signal triggers the Print cycle
2. The encoder signal determines the speed of the substrate.
3. The ribbon is accelerated to match the substrate speed.
4. The printhead is moved to the print position.
5. The required information is printed. (The printhead has no linear motion).
6. The printhead retracts and the ribbon is returned ready for the next print.

SmartDate X60 is now ready for the next print sequence.



■ Print Cycle SmartDate X60 - Shuttle Continuous Printer

The SmartDate X60 Shuttle Continuous has a print area of 53 mm x 100 mm and print speeds of 30 to 1000 mm/s.

High Speed mode 30 to 1200 mm/s

Digital Ribbon Save mode 30 to 1800 mm/s

The SmartDate X60 Shuttle Continuous prints while the substrate is moving. In this case the printhead only moves out to the print position and has no linear motion.

A shaft encoder is used to track the substrate speed.

The ribbon speed is accelerated up to match the substrate speed before printing can occur. This is done by means of the shuttle, which is driven by a stepper motor.

The use of a Shuttle enables the SmartDate X60 to print at very high print speeds.

This makes it the ideal coder for continuous motion form fill and seal machines and horizontal flow wrappers, where the image size is below 100mm in length and high speed is an issue.

One significant additional feature for this machine, however, is that it also has Cost Saving mode which increases print speed by 50% - from 1 m/s to 1.8 m/s of printing.

The operating sequence is:

1. A Print Go signal triggers the Print cycle.
2. The encoder signal determines the speed of the substrate.
3. The Shuttle is accelerated to match the substrate speed.
4. The printhead is moved to the print position.
5. The required information is printed. (The printhead has no linear motion).
6. A ribbon shuttle, in the Printer Cassette, is used to match the ribbon speed to the substrate.
7. The printhead retracts and the shuttle returns to its home position.
8. The ribbon is wound on so that unused ribbon is ready for the next print.

SmartDate X60 is now ready for the next print sequence.



■ Operating Modes

SmartDate X60 has one standard mode of operation, with the option to select additional ribbon save modes if required

These can be separated into two main groups:

■ Non-Ribbon Save Modes

Non-Ribbon Save Modes include:

- High Pack Rate - speeds of up to 700 mm/sec
- High speed mode - speeds of up to 1200 mm/sec

■ Ribbon Save Modes

Ribbon Saving modes include:

- Radial Ribbon Save Mode
- Interlace Mode
- Cost Saving Mode

The choice of mode will depend on the type of application and the operator's main objectives:

- If saving ribbon is the main objective, choose one of the Ribbon Save mode options.
- If print quality or speed is the main objective, choose one of the Non-Ribbon Save mode options.

A brief explanation of the different modes follows.

■ Printer Specific Print Options

▣ SmartDate X60 - Intermittent mode

This SmartDate X60 can be set to:

- High Pack Rate Operation
- Radial Ribbon Save Mode
- Interlace Mode

▣ SmartDate X60 - Continuous mode

This SmartDate X60 can be set to:

- High Pack Rate Operation
- Radial Ribbon Save Mode
- Interlace Mode
- High Speed Mode

▣ SmartDate X60 - Shuttle Continuous

This SmartDate X60 SmartDate X60 can be set to:

- High Pack Rate Operation
- Radial Ribbon Save Mode
- Interlace Mode
- High speed Mode
- Digital Ribbon Save Mode

Note: Hi Speed mode is disabled if Cost Saving Mode is selected.

Certain conditions will determine the standard of print quality achieved:

- The Substrate material being used
- The type of Ink Ribbon being used.
- The Speed at which printing is performed.
- The air pressure setting
- The Printer parameter settings
- The gap between the printhead and roller or platen.

The correct combination of all of these will greatly improve print quality.



■ High Pack Rate Mode

SmartDate X60 transfers ink from the ribbon directly onto the substrate by means of a thermal transfer printhead. In this mode the ink removed from the ink ribbon will be equal in size to the printed image on the substrate.

For example, a 2 mm long print will use 2 mm of ribbon.

This is the normal running mode for SmartDate X60 and will usually achieve the best print quality results. SmartDate X60 printers use Digital Ribbon Management (DRM) this means that the processor is constantly monitoring the ribbon movement.

Digital Ribbon Advance (DRA) means that the gaps between each print is kept to a minimum. This is achieved by the way the printers move the ribbon forwards and backwards using the waste ribbon for acceleration.

The maximum print speed for this mode is 700 mm/sec. (Intermittent Mode)
The maximum print speed for this mode is 1000 mm/sec. (Continuous Mode)

High Pack rate mode offers printing at the fastest possible rate at the highest quality level. This is the closest equivalent to the outdated Normal mode. The difference is that High Pack Rate mode can tune the acceleration times in accordance to the maximum substrate speed the printer is expected to print on.

Important: Obtaining the best performance therefore demands entering an appropriate value for this into the Max Substrate Speed setting.
The exact operation of High Pack Rate mode is depicted in the diagram below.

■ High Speed Mode

Not available with the SmartDate X60 when it is in Cost Saving mode.

The benefit of High Speed mode is that a print speed of up to 1000 mm/sec can be achieved. 1200 mm/sec with the SmartDate X60.

This is accomplished by reducing the resolution of the print.

This option is useful when the substrate speed is high and a lower print resolution is acceptable.

High Speed mode is a unique Markem-Imaje feature that allows printing speeds of up to 1 m/s (dependent on the substrate and thermal ribbon used).

Using a unique way of driving the printhead (patent pending), increased print speeds can now increase maximum speeds achievable, usually without regard to the thermal ribbon or substrate used.

When running in High Speed mode, print resolution will be lower than normal (current) operation. However, when enabled, this mode will:

- Increase the possible linear speed up to 1000 mm/s on ideal applications for SmartDate X60.
- Increase the speeds obtained with low speed, higher permanency, resin/ hybrid ribbons on all SmartDate X60 models.
- Increase the possibility of use for low speed coloured ribbons for SmartDate X60 models.

All of the above benefits are achieved with pure speed matching so that SmartDate X60 will maintain the current high reliability.

To access the High Speed mode setup menu, see section 6 Menus - Print Features - Print Mode.



Operation

■ High Speed Options

High Speed mode is a menu-selected option.

When DISABLED, the printer runs as standard and produces the full density, high quality image as expected.

When the mode is ENABLED, the user can set the threshold from which it begins to operate.

This can range from 30 mm/sec to 700 mm/sec.

When High Speed mode is selected and the running speed reaches the selected threshold speed, the printer automatically changes to High Speed mode operation.

Once High Speed mode is operating, the resulting print quality is slightly lower than standard, but it offers all of the above listed benefits.

For information on how to enable High Speed mode, please refer to Section 6.

The following information is relevant to High Speed mode on the SmartDate X60:

■ Threshold (ON/OFF)

The DEFAULT setting for High Speed mode is DISABLED.

When DISABLED, the machine operates in normal operating mode where the print speed remains constant.

When High Speed mode is ENABLED, a threshold speed must be set.

Once High Speed mode is enabled, settings such as background energy levels are adjusted to optimise operation in High Speed mode. However, on certain substrates these energy levels may need to be manually adjusted to optimise performance.

Contact your Markem-Imaje Business Centre before attempting to perform these adjustments.



▣ Materials and Applications

High Speed mode is designed for applications where a small reduction in perceived quality is acceptable so the customer may benefit from high running speeds. Primarily these applications are for simple Date & Lot type overprinting applications. High Speed mode can be used to print picket fence orientated barcodes, but must not be used to print Ladder format barcodes.

As for all applications, the customers material type should always be tested, however testing has proven SmartDate X60 High Speed mode to work well on various materials including: Polypropylene, Polythene, Premium labels and Laminated films. High Speed mode also increases the performance of the SmartDate X60 on “difficult to print on substrates” and “Harder to adhere ribbons”. High Speed mode will only operate reliably with Markem-Imaje-approved grades of Thermal Ribbon.

High Pack Rate Mode



High Speed Print Mode



Operation

▣ Limitations

The use of High Speed mode has major speed benefits to the customer, however, there are some points of this feature which must be considered when qualifying an application.

- When High Speed mode is selected, the maximum print speed is 1000mm/ sec.
- When High Speed mode is enabled the print quality will be reduced from the high quality achieved in standard mode.
- Just as today, where not all applications will achieve 600 mm/sec, for the new machines not all applications will achieve 1000 mm/sec. Application qualification is required to determine maximum speed, and the threshold speed at which the threshold should be set.
- You will not be permitted to print in High Speed mode at speeds lower than 30 m/s. Printing in High Speed mode at very low speeds can lead to a damaged Printhead.
- High Speed mode may reduce the quality of certain bitmaps used.
- Due to the castellation of characters with High Speed mode, it is not recommended to print characters less than 2 mm high. The BOLD font types will typically provide more consistent results.



■ Interlace Mode

This is a SmartDate X60 printer function which is used to save ribbon. When Interlace Mode is being used the ribbon is only advanced every second print, effectively saving 50% of the ribbon being used. This method of printing does however decrease the contrast quality of the print, as only half the normal amount of ribbon is being used to print with.

Interlace mode also has speed limitations - 400mm/sec, and is not suitable for Barcodes or Graphics for example.

Interlace mode is best suited to Date and Lot type Overprinting where a small reduction in print quality is acceptable.

Interlace Mode uses each piece of thermal ribbon twice to produce a reduced density “draft mode” print, and halves ribbon costs, and doubles the time between ribbon changeovers.

To access the Interlace mode setup menu, see section 6 Menus - Print Features - Ribbon Save.

How it works

Interlace mode is a menu selected option. When OFF, the printer runs as standard producing a full density, high quality image. If interlace mode is selected (ON), then for the “First Print” a pattern is used to only transfer half of the ink, giving a reduced contrast print.

For the “Second Print”, the Printhead is energised differently to print the alternate image. The result being two “draft mode” prints for half the price of a full density print.

What Interlace Mode prints look like...

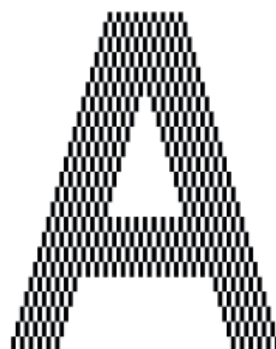

Operation

■ Setting up Interlace Mode

Once interlace mode is turned ON, settings such as background energy levels are automatically adjusted to optimise operation in interlace mode.

The settings should be optimised for a wide range of materials however a reality of interlace mode is that the first and second prints will differ slightly in contrast. Once the speed is set for the application, adjustment of the **Print Darkness** can be used to make these prints as equal as possible (balance the prints).

Typically, best results have been achieved with the printer set in the speed range of 150 mm/sec to 250 mm/sec (approx. 6"/sec to 10"/sec). The maximum print speed is recommended as no more than 400 mm/sec (15.7"/sec). If the first print is much darker than the second, reduce the **Print Darkness**. If the first print is much lighter than the second, increase the **Print Darkness**.

Only the **Print Darkness** parameter should be used to balance the prints. No other settings should be changed to balance the prints.

To access the Interlace mode setup menu, see printer Configuration - Print Features - Ribbon Save.



▣ Materials and Applications

Interlace mode is designed for applications where a small reduction in perceived quality (reduced contrast) is acceptable so the customer may benefit from halved running costs and increased uptime. Primarily these applications are for simple Date & Lot type overprinting applications. Interlace mode is not designed for bar-codes, graphics etc. The unique print achieved with Interlace Mode is however, ideal for applications which require a small amount of anti-counterfeit security, such as unique numbers for competitions.

The material type should always be tested, however testing has proven SmartDate X60 interlace mode to work well on various materials including: Polypropylene, Polythene, Premium labels and Laminated films. Typically, surfaces such as poorly calendared (rough / porous) paper and card which give poor results with standard Thermal Transfer Overprinting are not suitable for Interlace Mode.

Interlace Mode will only operate reliably with Markem-Imaje approved grades of Thermal Ribbon.

▣ Limitations

The use of interlace mode has major cost and uptime benefits, however, there are limitations of this feature which must be considered when qualifying an application.

- Ensure the materials are printed at the correct speeds, and that an acceptable “First” and “Second” print can be achieved.
- Due to the lower density, Interlace mode should not be used to print critical barcodes or automatically readable information.
- If the information to be printed changes between first and second prints (e.g. BBE Date increments) then some sections of the second print may be solid (full density) print rather than the chequered image. This will not decrease readability.
- It is not possible to achieve identical first and second prints. As the printer “warms up”, depending upon running speed the balance will change slightly. Also, as described above, the pattern will change first to second print giving a small difference.
- Due to the lower contrast achieved with interlace mode, it is not recommended to print characters less than 2 mm high. Check the legend depending upon font style selected. The BOLD font types will typically provide more consistent results in interlace mode.

■ Radial Ribbon Save Mode

In this mode, the ribbon is advanced only after the whole of the printable area of the ribbon has been used. For example, if the ribbon being used is 55 mm wide and each print is 10mm wide, SmartDate X60 can effectively print five times before advancing the ribbon. The position of each print however will be different on the Substrate.

Two methods are available, one for example would print five times then move the image back to the first position, but with the ribbon advanced. (Similar to an old typewriter) The other would reverse the order of prints after advancing the ribbon and snake from side to side on the ribbon.

Dependent on the image size, up to eight prints can be performed across the ribbon width before the ribbon is advanced.

This mode is useful if Lot codes or Best Before End Dates are being printed and the final position of the text on the Substrate is not an issue. Using a larger ribbon than normally required will save downtime.

To access the Radial Ribbon Save setup menu, see printer Configuration - Print Features - Ribbon Save.

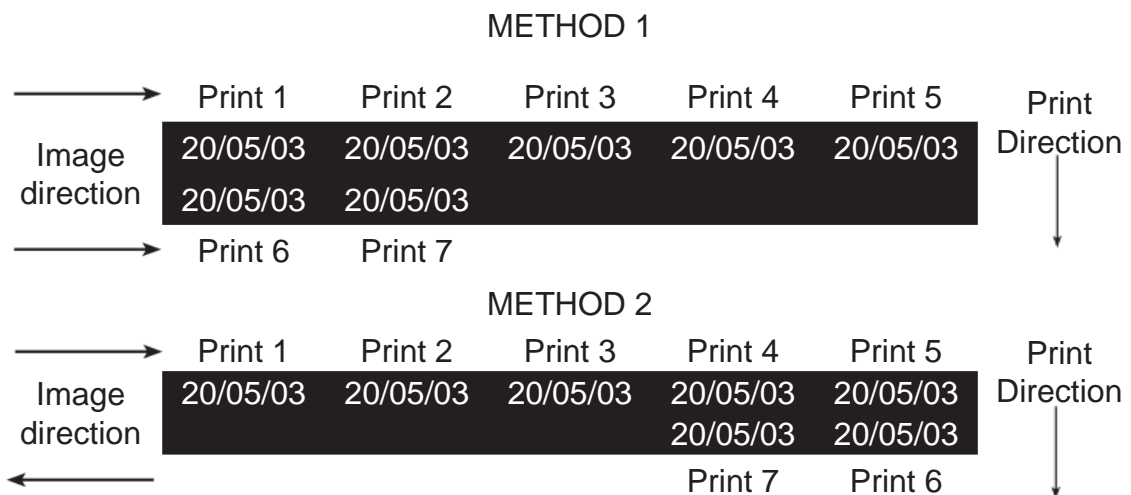

■ Digital Ribbon Save Mode

Digital Ribbon Save mode is a feature of the SmartDate X60 printer that allows you to reduce the amount of ribbon used for each print.

This is achieved by allowing the substrate to run at a faster speed than the ribbon. The difference between the ribbon speed and the substrate speed defines the amount of ribbon saving that can be achieved.

For example: If the substrate speed is 1.5 times that of the ribbon speed, then there is a ribbon saving of 1/3 (33%)

When the ribbon moves at a different speed to the substrate, the size of print is still as designed. This is achieved by stretching the amount of ink removed from the ribbon over a larger area.

An example of this might be as follows:

- Substrate running at twice the ribbon speed:
- A 10 mm long print on the substrate would only use 5 mm of ribbon.
- Substrate running at three times the ribbon speed:
- A 9 mm long print on the substrate would only use 3 mm of ribbon.

Digital Ribbon Save mode offers lower costs by using less ribbon per print than high pack rate mode. Three levels of ribbon saving can be selected. As less ribbon (and therefore less ink) is used per print there is a drop off in print quality as the ribbon saving level increases:

- **Lowest:** Offers a 10% reduction in ribbon usage with a print quality comparable to High Pack Rate mode.
- **Low:** Offers a 20% reduction in ribbon usage with a print quality slightly lower than High Pack Rate mode.
- **Medium:** Offers a 30% reduction in ribbon usage with a print quality lower than the High Pack Rate mode.
- **High:** Offers a 40% reduction in ribbon usage with a print quality noticeably lower than the High Pack Rate mode.
- **Highest:** Offers a 50% reduction in ribbon usage with a print quality significantly lower than the High Pack Rate mode.

To access the Cost Saving mode setup menu, see section 6 Menus - Print Features - Print Mode.

Operation

Three main points must be clearly understood:

1. The print in Cost Saving Mode mode will be fainter than with Normal or Hi Speed.
2. The higher the Cost Saving Mode setting the fainter the print will be as it is using less ribbon.
3. The correct set up of the SmartDate X60 is critical as the print gap distance and changes in air pressure for example will affect the print quality.

The prints as they would appear on the ribbon and substrate by using different Cost Saving Mode setting.



Image on Ribbon



Image on Substrate

None

Medium

Highest

Note: In situations where the substrate runs very slowly it is possible for the ribbon to run faster than the substrate in order to achieve a print.

Minimum and Maximum Print Speeds

There is a minimum and maximum print speed at which a particular ribbon saving will occur. For SmartDate X60 the minimum and maximum speeds are calculated as follows:

Minimum speed for selected ribbon save (mm/s) = 120 * substrate speed multiplier.

Maximum speed for selected ribbon save (mm/s) = 800 * substrate speed multiplier.

where:

substrate speed multiplier = $1 / (1 - (\text{ribbon save percentage} / 100))$

For example:

If the Digital Ribbon Save Mode setting is "Medium" the substrate runs at approximately 1.5 times the ribbon speed. The substrate speed multiplier is 1.5 resulting in a Minimum speed of 180 mm/s ($120 * 1.5$) and a Maximum speed of 1200 mm/s ($800 * 1.5$). Above the maximum ribbon save speed, SmartDate X60 automatically increases the substrate speed multiplier to achieve the closest possible ribbon saving to the initial value. This occurs until a speed of 1800 mm/s is reached - this is the absolute maximum print speed.

Below the minimum ribbon save speed, the SmartDate X60 automatically reduces the substrate speed multiplier to achieve the closest possible ribbon saving to the initial value. This occurs until a speed of 120 mm/s is reached at which point the substrate speed multiplier will remain at 1 (i.e. a ribbon saving of 0) down to 70 mm/s.



Operation

Absolute Maximum Speed

The absolute maximum speed for Digital Ribbon Save Mode is specified as 1800mm/s. This speed can be achieved using a ribbon saving of 56%. The SmartDate X60 will allow ribbon saving above 56%, however the SmartDate X60 will only operate to a maximum speed of 1800mm/s. The maximum achievable ribbon saving is 67% (when the substrate is running at 3 times the ribbon speed).

Absolute Minimum Speed

There is an additional function which Digital Ribbon Save Mode can provide to customers who want to keep printing while the packaging machine is slowing down (typically to ensure the last print is completed). If Digital Ribbon Save Mode is turned on, regardless of the ribbon save percentage, then the minimum print speed for the SmartDate X60 reduces from 70mm/s to 30mm/s. Below 70mm/s the SmartDate X60 reverses the Digital Ribbon Save Mode operation and runs the ribbon faster than the substrate, so that each dot is longer on the ribbon than on the substrate – this mode wastes ribbon but enables the SmartDate X60 to continue printing down to its absolute minimum print speed of 30mm/s and is typically used to complete the last print when the packaging machine is stopping.

This mode can only safely be used with images up to 42mm long. This is because the image on the ribbon is longer than the image on the substrate and at the absolute minimum speed of 30mm/s an image length of 42mm on the substrate requires 100mm of ribbon. The SmartDate X60 will not prevent this mode being used with longer images and will attempt to complete the print if possible (for example, if the speed is higher than 30mm/s or some of the image has been printed at a higher speed). The SmartDate X60 will issue a warning if it can not complete a print.



■ Relative Motion

The Relative Motion option is available on the Combined versions of the SmartDate X60 only.

It can be used with both the Intermittent and Continuous options of the Combined printers.

Relative Motion allows the SmartDate X60 to finish off a print that has been interrupted during the normal printing process.

To access the Relative Motion mode setup menu, see section 6 Menus - Print Features.

When using standard printing conditions the SmartDate X60 will behave in the following ways:

Intermittent mode:

When printing with the SmartDate X60 in Intermittent mode, the substrate is required to be stationary while printing takes place. If the substrate starts to move before the print is complete, the resulting print will be elongated or compressed depending on the direction of the substrate motion.

- If the substrate is moving in the same direction as the printhead carriage the print will be compressed.
- If the substrate is moving in the opposite direction from the printhead carriage the print will be elongated.
- In both cases there is a high risk that the ribbon will break.

Continuous mode:

When printing with the SmartDate X60 in Continuous mode, the substrate is required to be in motion while printing takes place. If the substrate stops moving during the printing process, the resulting print will be incomplete.

Relative Motion allows you to configure the SmartDate X60 so that it will complete the interrupted print. There will however be limitations in the length of the original print. This is because of the available movement of the printhead carriage.

With Intermittent mode this will depend on the amount of movement already used by the print carriage.

With Continuous mode this will depend on the limited amount of movement around the print roller.

Operation

How does it work?

Relative motion works in the following ways:

Intermittent mode:

When using Intermittent mode the printer must be fitted with an encoder to monitor the substrate speed. A high resolution encoder is recommended.

Example:

- The printer is set to print at a print speed of 300mm/sec.
- The substrate travels in the same direction as the printhead carriage.
- The normal speed of the substrate when in motion is 200mm/sec.
- The substrate starts to move before the print is complete.
- The SmartDate 5 then has to increase the print speed to match the new conditions (300 mm/sec + the substrate speed 200 mm/sec) 500 mm/sec.

The SmartDate X60 also has to accelerate the ribbon to match the substrate speed in order to complete the print without compressing it.

Note: If the substrate is moving when a Print Go signal is received, a warning is issued and no print occurs.

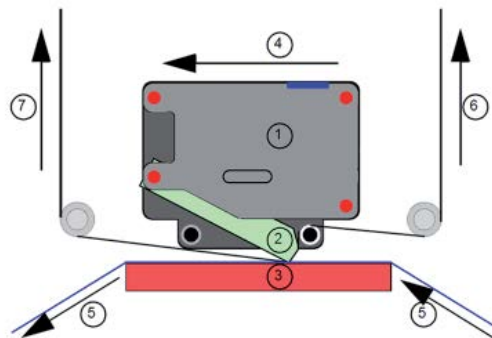

1. Printhead carriage.
2. Printhead.
3. Print platen.
4. Direction of carriage during printing.
5. Direction of Substrate when in motion.
6. Direction of ribbon travel after print (ribbon take up)
7. Direction of ribbon during Relative motion.

Continuous mode:

When using Continuous mode, the printer uses the encoder to determine if the substrate has stopped moving before the print is complete.

The SmartDate X60 will then move the printhead carriage in the direction of the unfinished print while following the contour of the print roller before returning to the normal print carriage position.

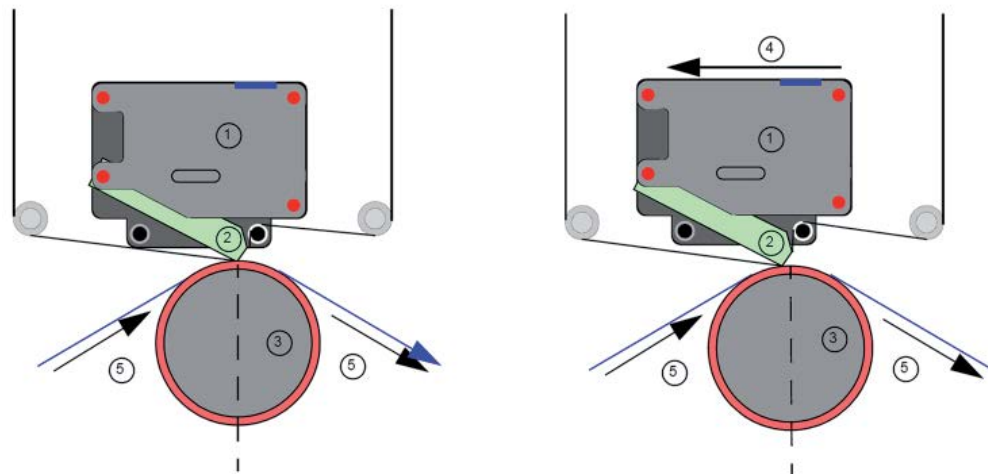

1. Printhead carriage.
2. Printhead.
3. Print roller.
4. Direction of carriage during relative printing.
5. Direction of Substrate.

The maximum amount of travel available for the printhead carriage is set via the SmartDate X60 menus.

For a standard Markem-Imaje 46 mm diameter roller this is 9 mm. The Relative motion function will be initiated if the substrate speed drops below the minimum print speed setting, and the amount of print left is less than the maximum relative print travel minus the end border. If this is not achievable the normal low speed print handling will be initiated.

A high resolution encoder is recommended.

■ Low Speed Print Mode

This is a Continuous printer option.

SmartDate X60 Continuous can be set to react in several different ways, if the Host packaging machine stops during the print cycle.

To access the Low Speed Print Mode setup menu, Printer Configuration - Machine.

The options are:

- None
- Continue
- Reprint

▣ None

This is the Default setting.

In this mode if the Host machine stops during a print cycle, the SmartDate X60 will lift the printhead and wait for the packaging machine to re-start.

During this time the option to Discard the print will be displayed on the screen.

If the print is not discarded, and the substrate starts to move again, the SmartDate X60 will continue with the print. The image in this case may have a small part of the print missing, as the printer requires time for the head and the ribbon to move.



▣ Continue

Associated with this mode is the Discard Print Time.

In this mode if the Host machine stops during a print cycle, the SmartDate X60 will lift the printhead, and wait for the Discard Print Time to elapse.

During this time the option to Discard the print manually will be displayed on the screen.

If the substrate starts to move again before the Discard Print Time has elapsed the SmartDate X60 will continue with the print. The image will restart once the printhead is down and the ribbon speed is above the minimum print speed . This may mean a gap in the printed image without any loss of information.

If the print is not manually discarded and the packaging machine does not re-start before the Discard Print Time has elapsed the print will be automatically discarded.

SmartDate X60 will then continue with the next print signal.

▣ Reprint

If the previous situation is not acceptable, the Reprint option may be used.

In this case the procedure is as for Continue, but when the substrate starts to move again the whole image will be reprinted.

The position of the printed image will differ slightly from normal.

NOTE: When low speed handling is set to Continue or Reprint the SmartDate X60 will track the substrate (once the print has started), even when the substrate speed has dropped below the minimum print speed. This means that if the substrate is jogged at low speed (i.e. less than min. print speed) past the printer the ribbon could wind indefinitely. To prevent this a limit of (image length +100mm) has been applied after which the print will be automatically discarded and the printer will wait for the next print go signal. In general if you want to pull substrate past the printer at below the minimum print speed you should first take the printer out of 'producing'.



Operation



Job selection



Job selection



■ Introduction

Topics covered in this section include:

- Job Setup Screens
- Data Entry Screens
- Date Entry Screens

■ Job Setup Screens

Job setup can be performed with the SmartDate X60 in a Stopped condition or with it in Producing mode.

Ready:

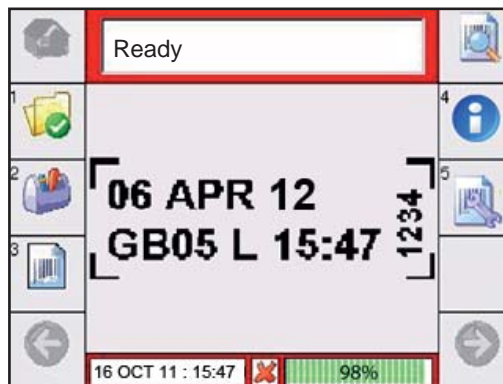

Producing:



Job selection

■ Job Setup Menus

SmartDate X60 provides several different ways of selecting a new Job. Job Setup depends if the Default Job is to be used, or where Job information is stored. e.g. In the SmartDate X60 Local database or at a Host PC running CoLOS Control.

■ Job Setup using the Default Print Design.

This option allows you to enter up to four lines of text at the User interface. The size and type of font is limited to 8 point Arial bold.

This type of design does not support live updates, such as Time and Date fields, Best Before Dates or Shift Codes.

1

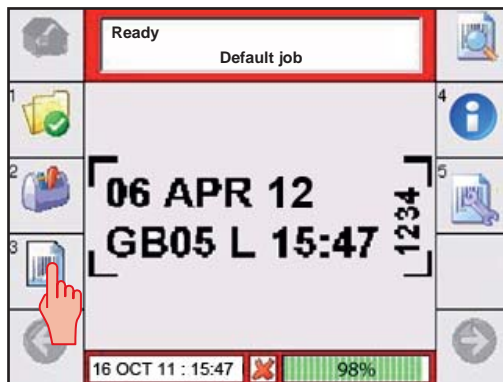

From the Home screen press the Select Job button under the main screen or use the Select Job option from the Menu screen.

2

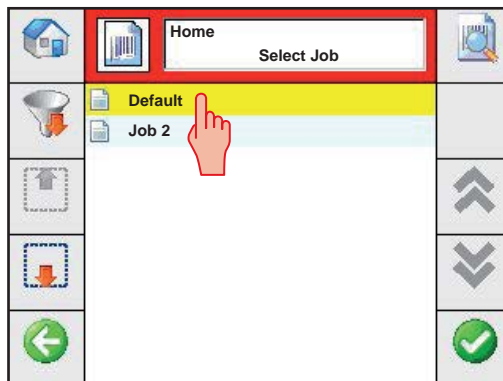

Select the Default job from the from the list available.

Job selection

3





Enter any required data in the four available fields.

Use the Alphanumeric keypad option



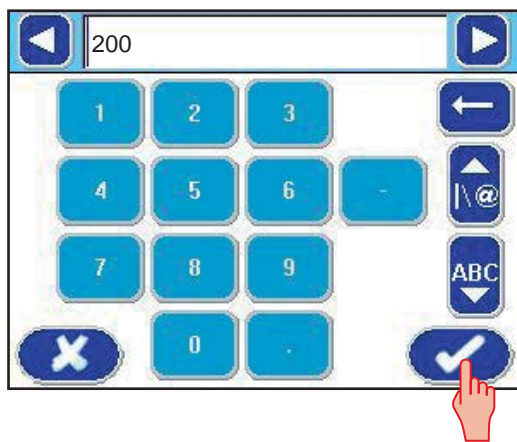

4

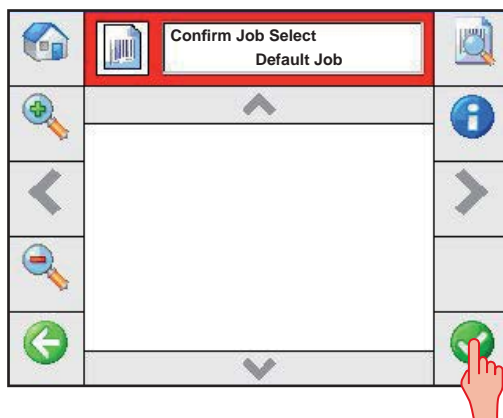

After entering individual field data, confirm this by selecting the tick  at the bottom right of the Alphanumeric screen and then use the right arrow  to move to the next field.

5



When complete, confirm this by selecting the tick  at the bottom right of the screen.

Job selection

▣ Using CoLOS Create Pro

These designs allow for much more functionality to be added to the Image such as:

- Barcodes
- Time Date fields
- Date Offset fields
- Machine ID fields
- Shift Codes

For full information about CoLOS Create Pro please consult the relevant documentation.

Print designs created on CoLOS Create Pro can be incorporated into a Job file and then stored in the SmartDate X60 local database or on a Host PC running CoLOS Control.



Job Setup using the Local Database

To select a Job by this method follow the procedure below:

1

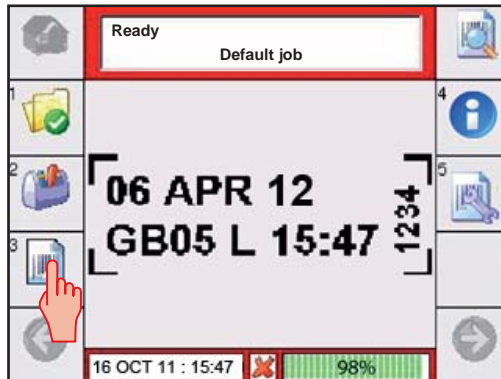

From the Home screen press the Select Job button under the main screen or use the Select Job option from the Menu screen.

2

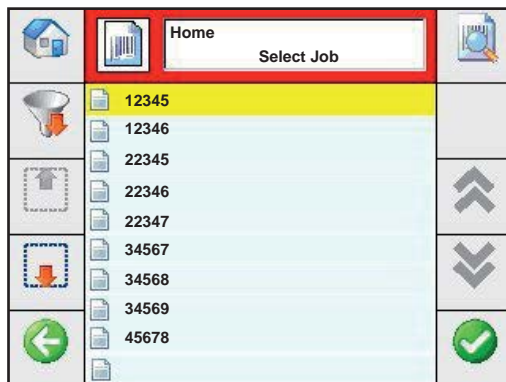

Select the required job from the list available.
Alternatively use the Filter function to find the required Job.
(See Filtering the list of Job names)



Once the required Job has been selected you may be prompted to add additional information to the Job.

For example:
User Input text. Such as a Barcode number
Operator Identification code.
BBE information.

Job selection

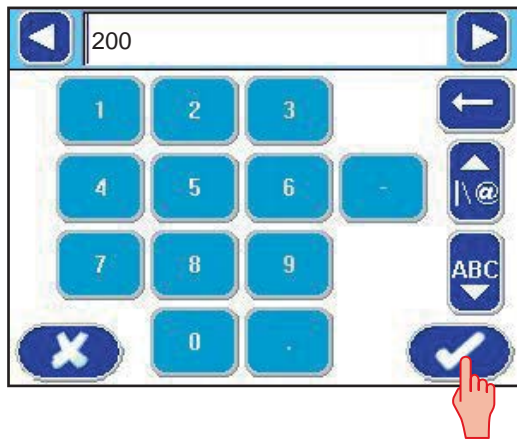
3



After entering individual field data, confirm this by selecting the tick  at the bottom right of the Alphanumeric screen and then use the right arrow  to move to the next field.

4

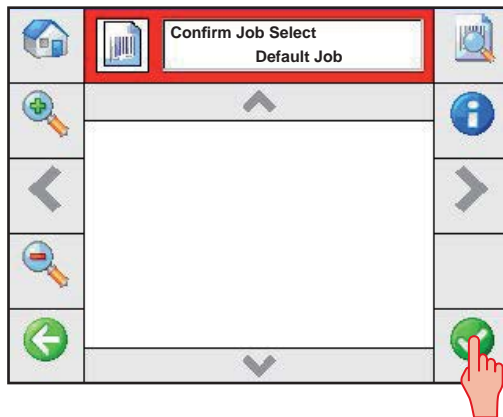

When complete, confirm this by selecting the tick  at the bottom right of the screen.

▣ Filtering the list of Job names

There may be hundreds of Jobs in the local SmartDate X60 database. The filter option can be used to make searching for a specific job easier.

1

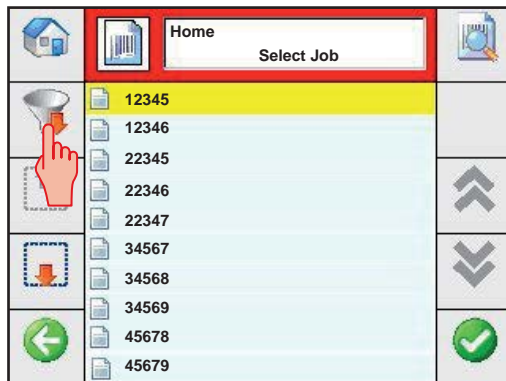

Selecting the Filter option displays the Alphanumeric screen.

2

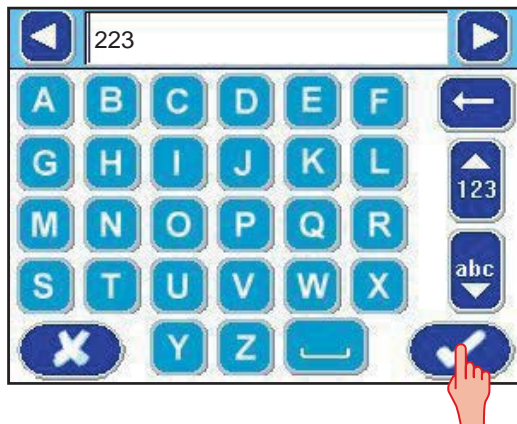

Enter the required characters or numbers by using the Alphanumeric screen buttons. When complete, select the Tick symbol  at the bottom right of the screen to activate the filter.

3

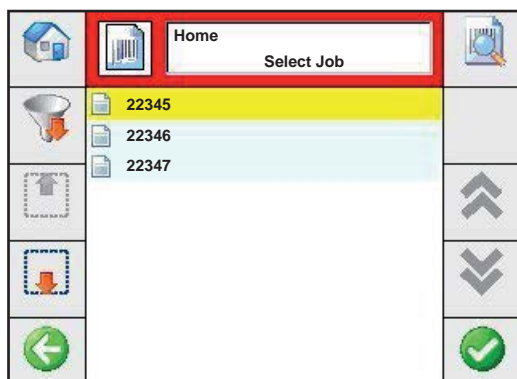

The Jobs beginning with the requested characters are displayed.

If the list of Jobs is still large, the search can be refined again to limit the number displayed.

Job selection

Job Setup using a Host PC

To select a Job with this method follow the procedure below:

1

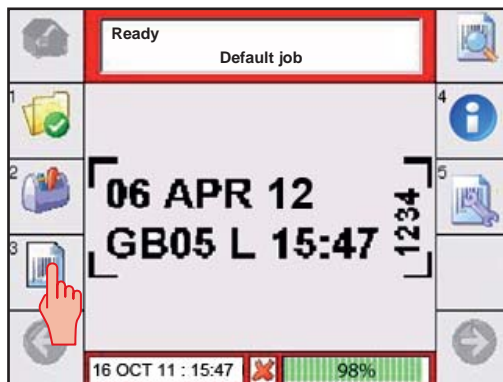

From the Home screen press the Select Job button under the main screen or use the Select Job option from the Menu screen.

2

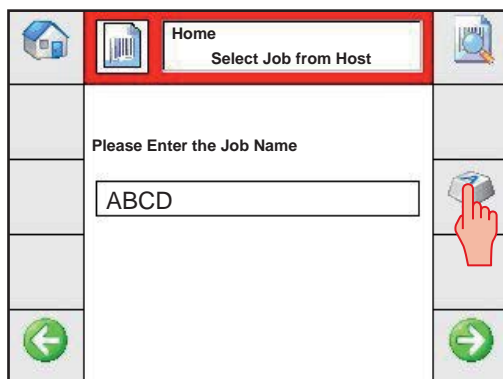

Enter the job name using the Alphanumeric screen.

Job selection

3

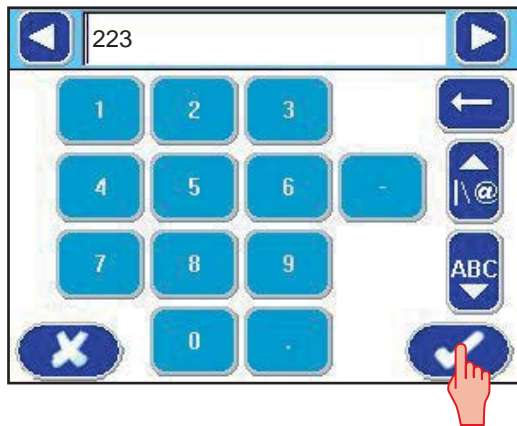

When complete select the tick  at the bottom right of the Alphanumeric screen.

4

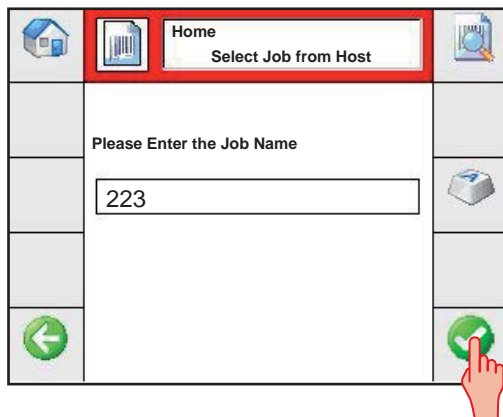

The Select Job screen is again displayed, press the right  button to Confirm.

The Job file will be retrieved from CoLOS Control and loaded into the SmartDate X60 printer memory ready for printing.

Job selection

▣ Prompted Data

Prompted data entry screens collect input from the user as a result of Job designs that require variable data to be entered during the Job selection process.

Because the Job design can prompt for different types of input, the screen types vary.



The type of data to be entered is configured by selecting the  button to the right of the data entry pane.

The data entry screen is displayed, allowing you to select Numeric, Alpha, Language specific characters or Symbols.

■ Date Entry Screens

There are three types of “Date Entry” screens that the User Interface has to support:

- Literal Date Entry
- Fixed Format Prompted Date Entry
- Offset Date Entry

▣ Literal Date Entry

This screen is used to prompt the setting of a fixed date to be printed. There is no calculation made on this date, it is displayed (Prompted) in the format that it will be printed. This means that the fields that make up the date string, can appear in any order, depending on how it was set at the design stage.

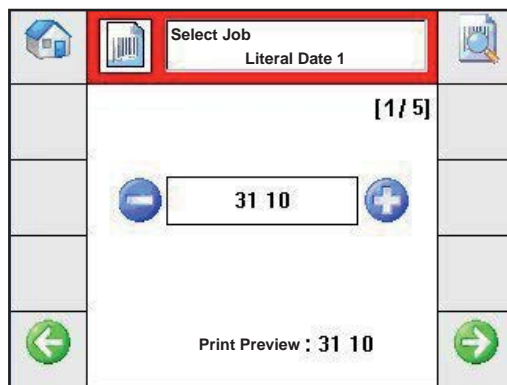

If required use the Blue + and - buttons to change the date before printing. Alternatively use the Calendar function to alter the date.

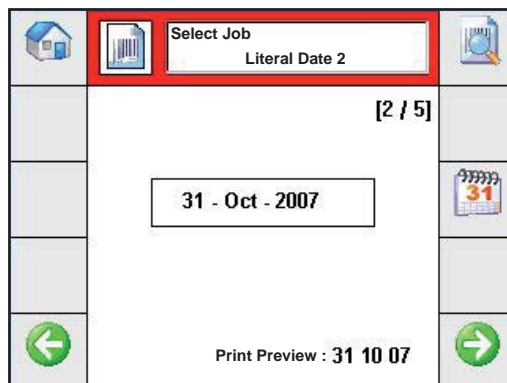

Job selection

▣ Fixed Format Date Entry

This screen is used to set a literal date to be printed, but this time the date is displayed in a fixed format. An example of where this option may be used is where the product is destined for another country. The user can set the date in their native language, and the preview will display how it will be printed in the other language.

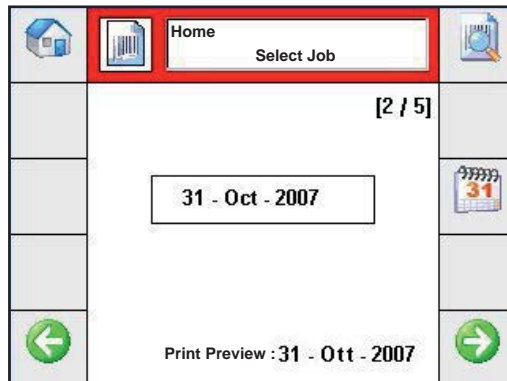

▣ Calendar



Offset Date Entry

This screen is used to set an offset from the SmartDate X60 internal clock and to preview what the resultant date would be.

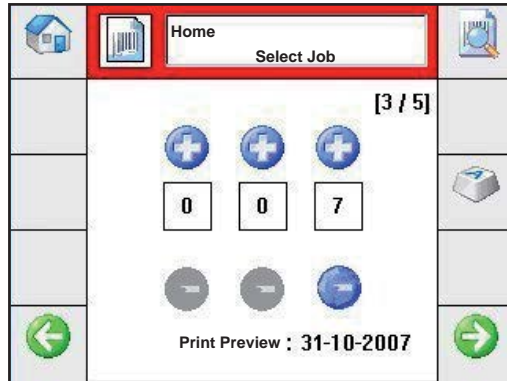

This example shows an offset of seven days, so the actual date that the SmartDate X60 internal clock is set to is the 24th October 2007.

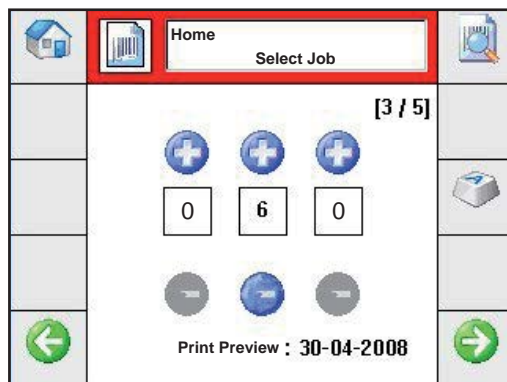

This example shows an offset of 6 months.

Job selection

■ Print Preview

This option allows you to preview the current selected job. From this screen you can zoom in on the details of the image or preview a detailed list of the image fields by selecting the  button.

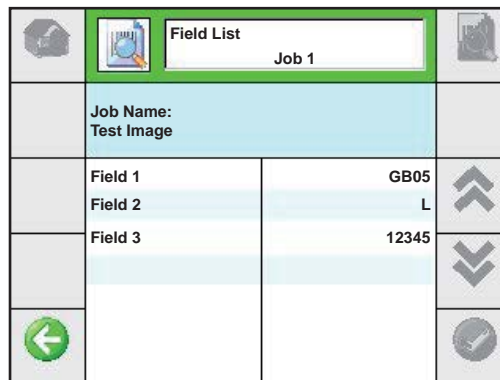
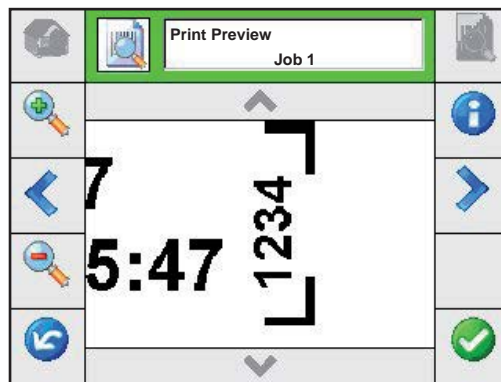

Field List		Job 1
Job Name:		Test Image
Field 1	GB05	⏏
Field 2	L	
Field 3	12345	⏏

■ Master-Slave Function

This allows you to configure one Smartdate (Set as the Master) to control the current job on another Smartdate (Set as the Slave)

When operating in this mode it is possible to:

Determine the basic operational state of the Slave printer from the Master SmartDate.

Determine if slaves are connected or not and if they are active printing.

Select jobs simultaneously accross two SmartDates (One Master + One Slave) entering any required data once only.

Jobs can be resident in each SmartDate local database, or these can be downloaded to Masters and /or Slaves from CoLOS Control.

Optionally, synchronise Start/Stop printing accross slaves.

Synchronise the clock date/time of the slaves to the master. The date and time are automatically synchronised when the Master connects to the Slave. The time / date can subsequently be adjusted either through the Master or from a third party host (eg CoLOS)



■ Connecting Masters to Slaves

Master / Slave functionality uses Ethernet to support communication between units. When SmartDates need to be paired they can be connected to each other by using an Ethernet cross-over cable. Machines can also be Networked together using a Switch / Hub. This configuration also allows connection of the SmartDates to Host software (e.g. CoLOS Control) as well as each other.

■ Configuring the System

The Master / Slave function is configured on the SmartDate that is to be used as the Master. This is done through the NGPCL menu on the Master SmartDate. The number of Slaves, IP address and Synchronise Start /Stop options are configured from this screen. (See Printer Configuration)

You can also configure the Master to be in control of the Slaves printing process. When Start or Stop is pressed each Slave behaves accordingly. Whether or not you choose to do this depends on the type of application you are running. If you are using more than one SmartDate to print onto a single pack this setting set to “Yes” will be beneficial.

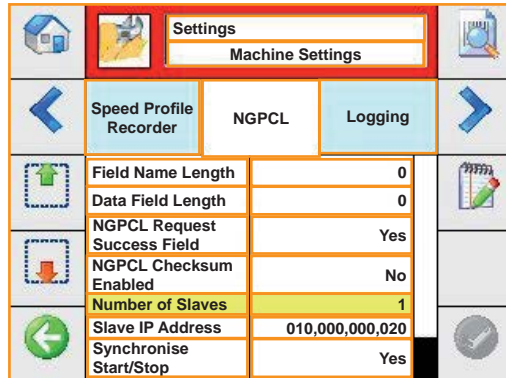

Settings	
Machine Settings	
Speed Profile Recorder	NGPCL
Field Name Length	0
Data Field Length	0
NGPCL Request Success Field	Yes
NGPCL Checksum Enabled	No
Number of Slaves	1
Slave IP Address	010,000,000,020
Synchronise Start/Stop	Yes

Printer configuration



Printer configuration



■ Introduction

This section describes how to navigate the menus and the options available.

Topics covered in this section include:

- Menu Structure.
- Printer Settings Menus
- Diagnostics Menus
- Statistics Menus
- Files Menus
- Service Menus
- Information about the printer Menu Structure



Printer configuration

■ Accessing the Menus

1

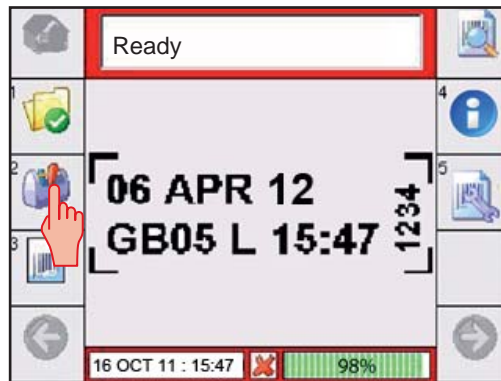

From the Home screen select Menu. .

If an Access Code is prompted for enter the code.

2

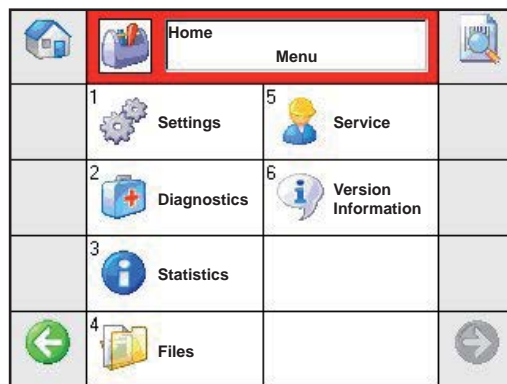

The Main Menu screen is displayed.

The Main Menu screen allows you to:

- Access the Settings Menu
- Access the Diagnostics Menu
- Access the Statistics Menu
- Access the Files Menu
- Access the Service Menu
- Access the Version Information

Certain menu options will only be displayed depending on the printer type selected.

- In the following menu trees (#) signifies that a constraint applies. See Settings constraints.

Printer configuration

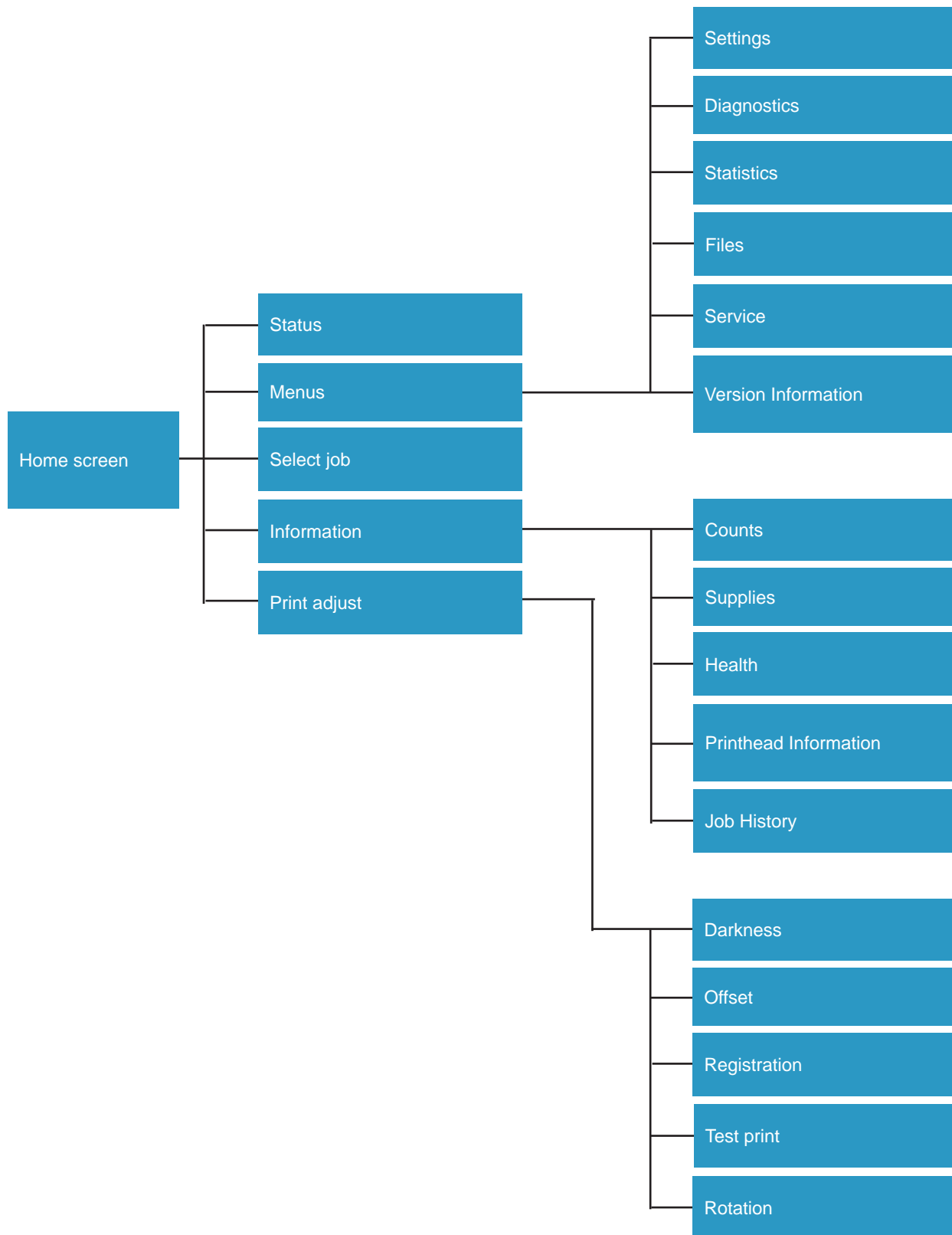

Printer configuration

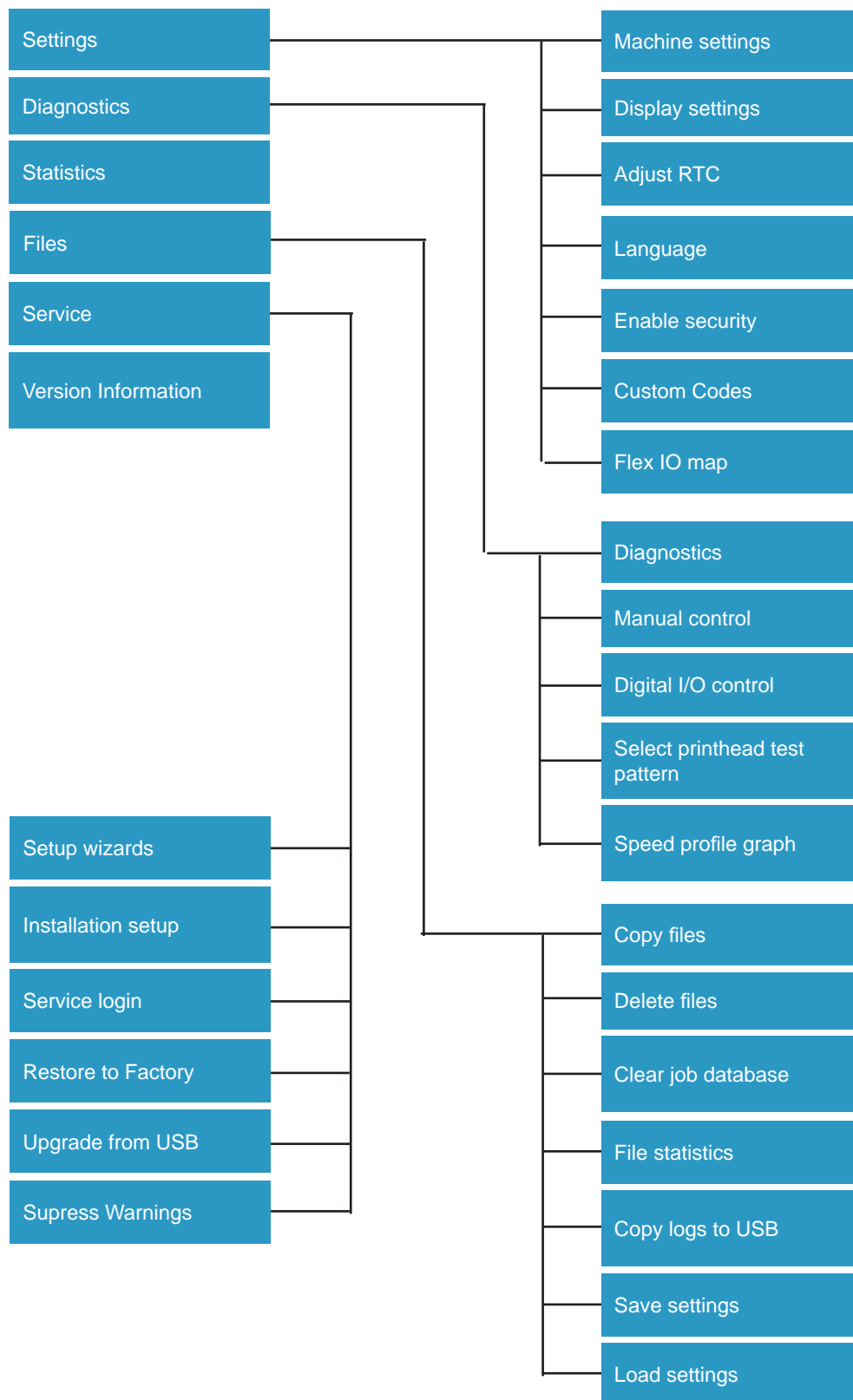

Printer configuration

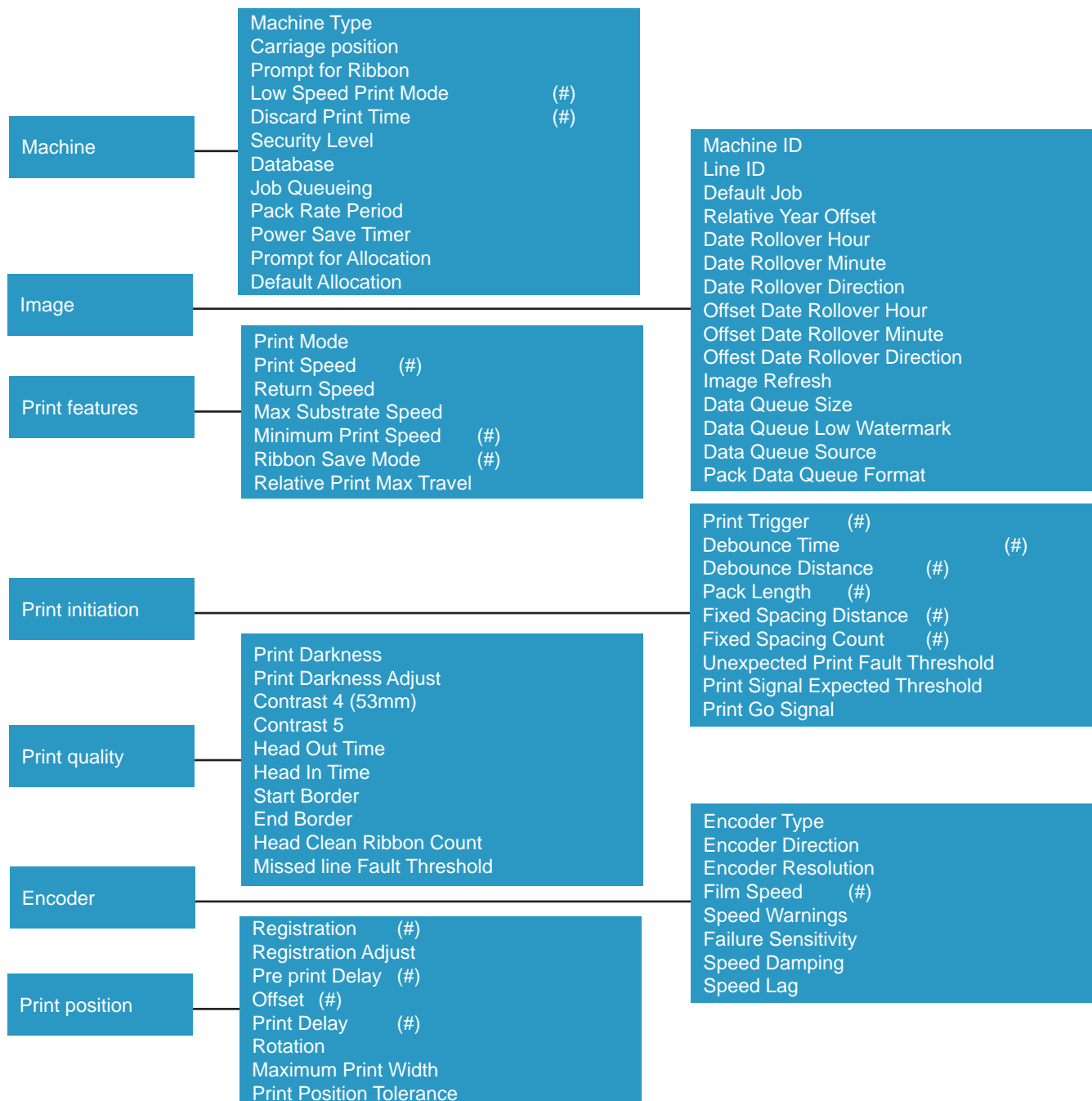

Printer configuration

Ribbon setup	<ul style="list-style-type: none"> Ribbon Grade Ribbon Colour (#) Ribbon Width (#) New Ribbon Length (#) New Outside Diameter (#) Core Outside Diameter (#) Ribbon Advance Distance Ribbon Spacer Width Ribbon Extra Wind
Ribbon Monitoring	<ul style="list-style-type: none"> Ribbon Break Detection Low Ribbon Detect Low Ribbon Size Low Ribbon Action
Comms	<ul style="list-style-type: none"> IP Address IP Subset Mask IP Gateway Serial Port 1 Serial Port 1 Function Serial Port 1 Baud Rate RS-232 Char Set Web ID
Speed profile recorder	<ul style="list-style-type: none"> Resolution (#) Trigger (#)
NGPCL	<ul style="list-style-type: none"> Field Name Length Field Data Length NGPCL Request Success Field Checksum Enabled
Master / Slave	<ul style="list-style-type: none"> Number of Slaves Slave 1 : IP Address Slave 2 : IP Address Slave 3 : IP Address Slave 4 : IP Address Sync Start /Stop
Logging	<ul style="list-style-type: none"> Variable Data Log Level Data Log Full Action Event Log Level
SSCC	<ul style="list-style-type: none"> SSCC Company ID SSCC Current Serial Reference Value SSCC Min Serial Reference Value SSCC Max Serial Reference Value SSCC Extension Digit
External	<ul style="list-style-type: none"> General Purpose 1 - 12

■ Settings Constraints

Some Settings menu items have constraints. i.e. They will only be displayed if certain settings conditions apply.

The following list shows which menu items have constraints and the conditions that apply:

All of the options are displayed with the top level password, some options are not displayed with lower level passwords.

Machine	
Low Speed Print Mode	Continuous printer only.
Discard Print Time	Continuous printers only and Low Speed print mode set to Continue or Reprint
Print Features Group	
Print Speed	Intermittent printer only.
Minimum Print Speed	Continuous printer only.
Ribbon Save	Intermittent or Continuous printer.
Print Initiation Group	
Print Trigger	Continuous printer only
Debounce Time	Intermittent printer
Debounce Distance	Continuous printer only
Print Go Ignore	Continuous printer only
Fixed Spacing Distance	Continuous printer only and print trigger set to Internal or Combined
Fixed Spacing Count	Continuous printer only and print trigger set to Combined



Printer configuration

Encoder

Encoder Type	Continuous printer only.
Encoder Direction	Continuous printer and Encoder Type set to Quadrature.
Encoder Resolution	Continuous printer and Encoder Type set to Quadrature or Pulse Train.
Film Speed	Continuous printer and Encoder Type set to Internal. Printer Mode dependant.
Speed Warnings	Continuous printer only.

Print Position

Registration	The maximum amount is dependant on the printer type.
Pre print Delay	Continuous printer only.
Offset	The maximum amount is dependant on the ribbon width.
Print Delay	Intermittent printer only.

Ribbon Setup

Ribbon Color	Markem-Imaje ribbons only, some colours not available with certain grades. Not available when Non Markem-Imaje selected.
Ribbon Width	Limited by printhead width selected.
Full Ribbon Size	Only displayed if Non Markem-Imaje ribbon selected.
New Outside Diameter	Only displayed if Non Markem-Imaje ribbon selected.
Core Outside Diameter	Only displayed if Non Markem-Imaje ribbon selected.
Tension Adjust	Maintenance Engineer Password Required.

Speed Profile Recorder

Resolution	Continuous printer and Encoder set to External
Trigger	Continuous printer and Encoder set to External.

■ Settings Menus

1

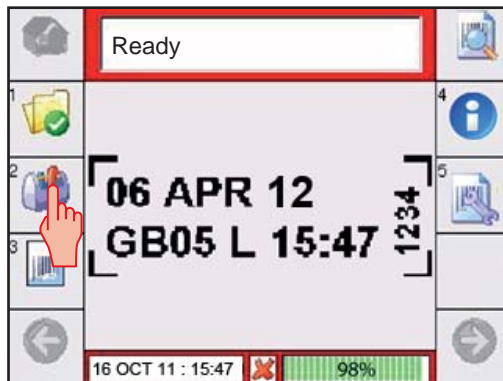

From the Home screen select Menu.

If an Access Code is prompted for enter the code.

2

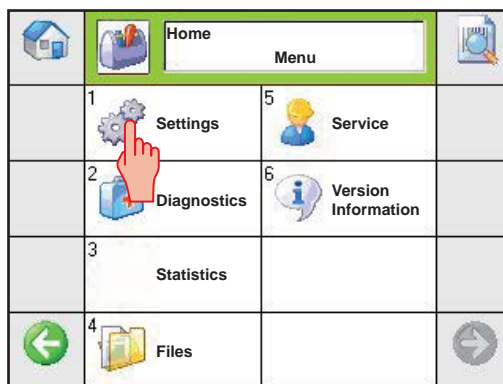

From the Menu screen select Settings

Printer configuration

3

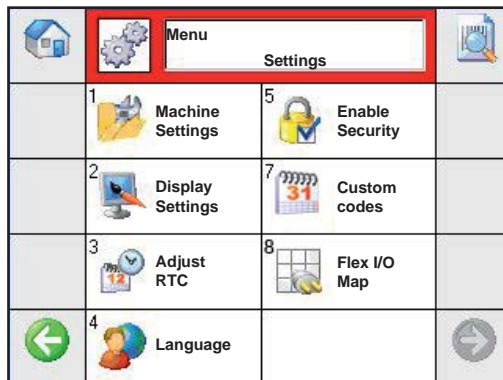

The Settings Menu screen is displayed.

The Settings Menus allow you to:

- Configure the Machine settings.
- Configure the Display settings.
- Configure the Real Time Clock (Set the Date and Time)
- Select the User Interface language.
- Enable or Disable the Security settings.
- Configure the Flexible I/O maps.

Most of these settings should only require configuring directly after installation. Some others, such as the Print Darkness may require periodic adjustment.

Machine Settings

1

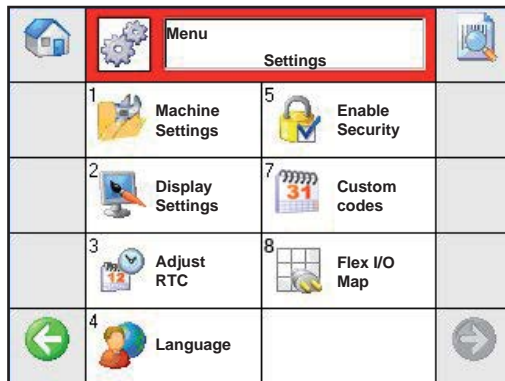

From the Settings screen select Machine Settings.

If an Access Code is prompted for enter the code.

2

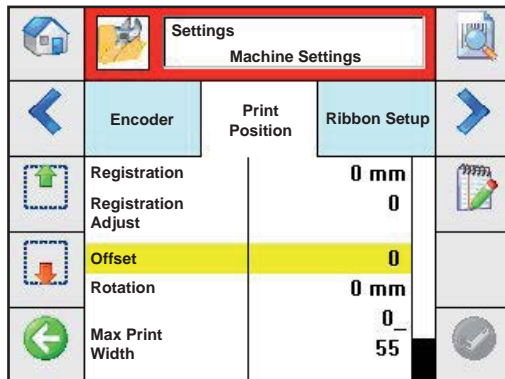

Use the Left and Right Arrows to move to the required set of options.

Use the Up and Down Arrows to select the setting to be configured.

Use the Notebook to configure the setting.

The Machine Settings Menus allow you to:

- Configure the Machine specific settings of the printer.
- Configure the Image settings.
- Configure the Print Feature settings.
- Configure the Print Initiation settings.
- Configure the Print Quality settings.
- Configure the Encoder settings.
- Configure the Print Position settings.
- Configure the Ribbon settings.
- Configure the Ribbon Monitoring settings.
- Configure the Communications settings (Comms)
- Configure the Speed Profile settings.
- Configure the NGPCL settings.
- Configure the Logging settings.
- Configure the External Scratch pad Registers



Printer configuration

■ Machine Options

The Machine menu allows you to configure various settings that are specific to the particular printer.

The following Machine options can be configured:

Machine Type Range: Continuous or Intermittent Default: Continuous	This allows you to configure the Smartdate X60 to Continuous or Intermittent operating mode.
--	--

Carriage Position	This allows you to set the position of the printhead module carriage when in continuous operating mode.
-------------------	---

Prompt for Ribbon Range: Yes, No Default: Yes	This allows you to enable the ribbon type prompt. When set to YES the user must enter a ribbon type when changing ribbon.
---	--

Low Speed Print Mode Range: None, Continue or Reprint Default: None	This is a Continuous printer function. This allows you to set which action should be taken if the host machine speed drops below the Low Speed Threshold.
---	--

Discard Print Time Range: 0 - 30s Default: 0s	This is a Continuous printer function. This allows you to set the time that the substrate must be stationary during a print before the print is discarded.
---	---

Security Level Range: Open or Medium Default: Open	This allows you to set a password level for your machine. Access codes are configured with CoLOS Control.
--	---

Database Level Range: Local or Host Default: Local	This allows you to select between using the local machine database or a remote host PC.
--	---

Printer configuration

Job Queuing

Range: Off, On, Repeat or Binary Select

Default: Off

This allows you to queue up to eight jobs to be printed in a sequence. For example: These jobs may have an allocation of 20 prints before the next job is selected. If repeat is selected each job in the queue will be printed once in the sequence.

Binary allows the jobs to be selected remotely and in any order from the queue.

Pack Rate Period

Range: 1 to 24 hours

Default: 1 hour

This allows you to set the time period over which the average pack rate is measured.

Power Saving Timer

Range: A user selected time or Off

Default: Off

This allows you to set a time before power saving is activated.

This de-energises the motors and printhead until power saving is de-activated.

Prompt for Allocation

Range: Yes or No

Default: No

This allows you to enable the allocation prompt function

After selecting a job the user will be asked how many allocated prints are required

Default Allocation

Range: 0 to 999999

Default: 0

This allows you to allocate a default number to prints as a standard setting.



Printer configuration

▣ Image

The Image menu allows you to configure various settings that relate to the image being printed.

The following Image options can be configured:

Machine ID
Range: 0000 -9999
(Including other characters)
Default: 0000

This allows you to set a four character, unique identification for each SmartDate X60.
The information is then printed in a specific field on the design.
This allows the same layout design to be used for several printers, with each printing a unique Machine ID.

The field in the design must be created as a Machine ID field in CoLOS Create Pro.

See CoLOS Create Pro for details.

Line ID
Range: 1 - 99
Default: 1

This allows you to set a identifying number for the product line that the SmartDate X60 is being used on.
The information is then printed in a specific field on the design.
The field in the design must be created as a Line ID field in CoLOS Create Pro.

See CoLOS Create Pro for details.

Default Job
Range: Enabled or Disabled
Default: Enabled

This allows you to enable or disable the Default Job feature.

Relative Year Offset
Range:
Default:

This allows you to set a relative year offset for Japanese Emperor years.
E.g. 1998 will be printed as year 10 and 2004 will be printed as year 16.

Date Rollover Hour
Range: 0 to 11
Default: 0

This allows you to set the hour at which the next day starts.

Date Rollover Minute
Range: 0 to 59
Default: 0

This allows you to set the minute of the hour at which the next day starts.

Printer configuration

Date Rollover Direction
Range: After Midnight or Before Midnight
Default: After Midnight
This allows you to set the period of the day that the rollover occurs.

Offset Date Rollover Hour
Range: 0 to 11
Default: 0
(Best Before End)
This allows you to set the hour at which the next day starts.

Offset Date Rollover Minute
Range: 0 to 59
Default: 0
(Best Before End)
This allows you to set the minute of the hour at which the next day starts.

Offset Date Rollover Direction
Range: After Midnight or Before Midnight
Default: After Midnight
(Best Before End)
This allows you to set the period of the day that the rollover occurs.

Image Refresh
Range: Every Second or every Minute
Default: Every Minute
This allows you to set the update period for viewing the selected job on the Home screen when in producing mode.

Data Queue Size
Range: 0 to 200
Default: 0
This is used with per-print variable data queueing. This allows the SmartDate to buffer field data for a number of packs ahead of the one being printed. Normally used in conjunction with weigh scale equipment and allows the weigh scale equipment to communicate information for the pack it has just weighed

Data Queue Low Water Mark
Range: 0 to 200
Default: 0
This allows you to set the limit at which an update request is sent to the host machine



Printer configuration

■ Print Features

The Print Features menu allows you to configure various settings that relate to the operation of the printer.

The following Print Features options can be configured:

Print Mode Range: High Pack Rate, High Speed or Digital Ribbon Save mode Default: High Pack Rate	This is a Continuous printer feature. This allows you to set the printing mode to suit the customers requirements. (See Operation for details)
Maximum Substrate Speed Range: 100 mm/s to 1000 mm/s Default: 600 mm/s	This is a Continuous printer feature. This allows you to set the maximum substrate speed that the printer can achieve a good quality print. Setting this value too high can result in distorted prints. (See Operation for details)
Print Speed Range: 70 to 600 mm/s Default: 100 mm/s	This is an Intermittent printer feature. This allows you to set the print speed for Intermittent printers.
Return Speed Range: 10 to 600 mm/s Default: 100 mm/s	This is an Intermittent printer feature. This allows you to set the speed of the printhead carriage during the return part of the print cycle. This also sets the ribbon wind speed.
Min Print Speed Range: 0 to 200 mm/s Default: 70	This is a Continuous printer feature. This allows you to set the minimum print speed for continuous printers.
Ribbon Save Mode Range: No Ribbon Save, Interlaced, Radial Mode 1 and Radial Mode 2 Default: No Ribbon Save	This allows you set the type of ribbon save function that you require. (See Operation for details)
Relative Print Maximum Travel Range: 0.0 mm to 30.0 mm Default: 0.0 mm	This is a Combined printer continuous mode feature. This allows you to set the maximum distance that the printhead module can move to complete a print if the host machine stops during the print cycle. (See Operation for details)

Printer configuration

■ Print Initiation

The Print Initiation menu allows you to configure the signal to start printing. The options available will depend upon which printer type is selected. (Intermittent or Continuous)
The following Print Initiation options can be configured:

Setting	Description
Print Trigger Range: External, Internal or Combined. Default: External	This is Continuous printer feature. This allows you to set the print trigger source.
Debounce Time Range: 0 to 5000 ms Default: 10	This is an Intermittent printer feature. This allows you to set the time over which the print trigger must be active before it is accepted as valid. This avoids electrical noise problems.
Debounce Distance Range: 0 to 5 mm Default: 0	This is Continuous printer feature. This allows you to set the distance over which the print trigger must be active before it is accepted as valid. This avoids electrical noise problems.
Pack Length Range: 0 mm to 1200 mm Default: 2 mm	This is Continuous printer feature. This allows you to set the distance following a valid print go signal that the printer will ignore subsequent print signals.
Fixed Spacing Distance Range: 10 - 2000 mm Default: 150 mm	This is Continuous printer feature. When the print trigger is set to Internal or Combined this allows you to define the distance between the leading edges of the prints on the substrate.
Fixed Spacing Count Range: 1 - 65535 Default: 1	This is Continuous printer feature. When the print trigger is set to Combined this allows you to define the number of prints following a Print Go signal.
Unexpected Print Fault Threshold Range: 0 to 100 Default: 10	This allows you to set the number of acceptable missed prints before a fault is raised.
Print Signal Expected Threshold Range: 0 to 1000 Default: 0	This is a Continuous printer feature. This allows you to set the distance that the substrate is allowed to travel without an expected print go signal and before a fault is raised.
Print Go Signal Range: Active Low or Active High Default: Active Low	This allows to to set the print trigger to be activated when high or low.

Printer configuration

■ Print Quality

The Print Quality menu allows you to configure settings that control the quality of the printed image.

The following Print Quality options can be configured:

Setting	Description
Print Darkness Range: 80 to 140% Default: 100%	This allows you to set the Darkness level for the print.
Print Darkness Adjust Range: -25% to +25% Default: 0	This allows you to set a printer specific darkness level for the printer. If a Job includes a print darkness setting this may produce different quality prints on individual machines. This adjustment compensates for any differences.
Contrast 4 Range: 60 to 99% Default:	This defines the contrast weighting when subsequent dots are driven (53mm printhead only)
Contrast 5 Range: 80 to 140% Default:	This defines the contrast weighting when adjacent dots are driven.
Head Out Time Range: 0 - 100ms Default: 25ms	This allows you to set the time delay between moving the head out and starting to print. This ensures that the Printhead is in position before printing starts.
Head In Time Range: 0 to 200 ms Default: 3 ms	This allows you to set the time delay between the end of print and the next stage of the print cycle.



Printer configuration

Start Border

Range:

0 to 20.0 mm

Default: 2.0 mm Intermittent

Default: 4.0 mm Continuous

This allows you to set the distance over which the printhead is allowed to settle after it has moved out, but before it starts to print.

End Border

Range:

0 to 20.0 mm

Default: 2.0 mm Intermittent

Default: 0.5 mm Continuous

This allows you to set the distance the printhead or ribbon is allowed to travel after printing, but before the printhead is retracted.

Head Clean Ribbon Count

Range: 0 to 1000

Default: 0

This allows you to set the number of rolls of ribbon that must pass the printhead before the Head Clean warning is issued.

Missed Line Fault Threshold

Range: 0 to 5000

Default: 0

This allows you to set the number of acceptable missed lines on an image before a fault is raised.



Printer configuration

Encoder

The Encoder menu allows you configure various settings related to the Continuous printer speed encoder.

The following Encoder options can be configured:

Setting	Description
Encoder Type Range: External Quadrature, Internal or External Pulse Train. Default: External Quadrature	This allows your to set the Encoder type for Continuous printers.
Encoder Direction Range: Clockwise or Anti-clockwise Default: Clockwise	This allows you to set the forward direction of a quadrature encoder.
Encoder Resolution Range: 2.8 to 150.00 pulses/mm Default: 3.05 pulses/mm	This allows you to set the number of pulses per mm for an External encoder.
Max Film Speed Range: 70 mm/s to 600 mm/s Default: 300 mm/s	This allows you to define the substrate speed for an Internal encoder.
Speed Warnings Range: Enabled or Disabled Default: Enabled	This is Continuous printer feature. This allows you to enable or disable the speed warnings option. When enabled this will provide a warning if the substrate is out of the acceptable speed range.
Failure Sensitivity Range: Off, Low, Medium or High Default: Off	This allows you to configure the sensitivity of the printer to incoming print signals when no encoder signal is detected.
Speed Damping Range: Off, Low, Medium or High Default: Off	For use on high-speed applications – controls smoothing of the encoder signal.
Speed Lag Range: 3.0% to 20% Default: 3.0%	For use on high speed applications – controls high-speed “tension control”

Printer configuration

■ Print Position

The Print Position menu allows you to fine tune the position of the print on the target material.

The following Print Position options can be configured:

Setting	Description
Registration Range: Continuous 0.0 - 600.0mm Intermittent 0.0 - 75.0mm Default: 0mm	This is Continuous printer feature. This allows you to set the start position of the print relative to the Print Go position. Intermittent printers This allows you to set the start position of the print module.
Registration Adjust Range: -10mm to +10mm Default: 0mm	This allows you to set a printer specific registration level for the printer. If a Job includes a registration setting this may produce different positioned prints on individual machines. This adjustment compensates for any differences.
Pre print Delay Range: 0 to 50 Default: 0	This is Continuous printer feature. This allows you to set the length of delay applied at the start of the print cycle.
Offset Range: 0 to ribbon width Default: 0mm	This allows you to adjust the print position perpendicular to the direction of print. (Across the printhead)
Print Delay Range: 0 to 5000 ms Default: 0 ms	This is an Intermittent printer option This allows you to define the time between the Print Go signal and the start of the print.
Rotation Range: 0 or 180° Default: 0	This allows you rotate the image through 180°
Maximum Print Width Range: 0 to 55 mm Default: 55 mm	This is used in conjunction with a ribbon spacer, where it is necessary to limit the amount of usable ribbon.
Print Position Tolerance Range: 0 or 10 mm Default: 2 mm	This is Continuous printer feature. This allows you to configure the position tolerance of the print on the packaging. A higher value here allows smaller gaps between the prints on the ribbon.

Printer configuration

▣ Ribbon Setup

The Ribbon Setup menu allows you to configure various ribbon specific settings. This enables the Controller to fine tune printer settings to suit individual ribbon types. The following Ribbon Setup options can be configured:

Setting	Description
Ribbon Grade Range: 3100, 3410, 3510, 3810, 3820, 3910, 4910, 5810, Non Markem-Imaje Default: 3810	This allows user to set the grade of the ribbon being used.
Ribbon Colour Range: BK, WE, GD, BE, BN, CN, GN, RD, YW. Default: BK	This allows user to set the colour of the ribbon being used. The options will depend upon the grade selected. No options with Non Markem-Imaje ribbon.
Ribbon Width Range: 20mm, 25mm, 30mm, 35mm, 40mm, 45mm, 50mm, 55mm. Default: 55mm	This allows user to set the width of the ribbon being used. The options will depend upon the printhead width selected.
New Ribbon Length Range: 100 to 900 Default: 900	This option is displayed if Non Markem-Imaje ribbon is selected. This allows you to set the length of ribbon being used.
New Outside Diameter Range: 40.0 to 100.0 mm Default: 98.0 mm	This option is displayed if Non Markem-Imaje ribbon is selected. This allows you to set the outside diameter of ribbon being used.
Core Outside Diameter Range: 30.0 to 35.0 mm Default: 32.0 mm	This option is displayed if Non Markem-Imaje ribbon is selected. This allows you to set the outside diameter of ribbon core being used.

Printer configuration

Ribbon Winding
Range: Inside Winding or Outside Winding
Default: Inside Winding

Depending on which side of the ribbon the ink is positioned, this allows you to configure the Inside or Outside option.

Ribbon Advance Distance
Range: 1 - 10mm (1 - 1000 mm*100)
Default: 1mm

This allows you to set the distance the ribbon advances between prints (in addition to the length of the print)
When using Radial Ribbon Save this should be set to a minimum of 2 mm.

Ribbon Spacer Width
Range: 0 to 55 mm
Default: 0

This allows you to configure the width of a ribbon spacer if one is being used.

Ribbon Extra Wind
Range: 0 to 600 mm
Default: 0

This allows you to configure the amount of additional wind on when a new ribbon is fitted or the cassette is opened.

▣ Ribbon Monitoring

The Ribbon Monitoring menu allows you to configure various settings related to the condition of the ribbon.

The following Ribbon Monitoring options can be configured:

Setting

Description

Ribbon Break Detection
Range: YES / NO
Default: YES

This allows you to set the ribbon break detection function.

Low Ribbon Detection
Range: Yes / No
Default: Yes

This allows you to set the low ribbon detection function.

Low Ribbon Size
Range: 10 - 100m
Default: 10m

This allows you to set the point at which the Low Ribbon warning is activated. When the remaining ribbon is less than this value, and the printer is in Producing mode, the Status LED changes to Amber and the Low Ribbon warning is displayed.
A value of 0 m disables the Low ribbon sensing.

Low Ribbon Action
Range: Warning or Fault
Default: Warning

Raise warning or raise fault.



Printer configuration

▣ Communications

The Comms menu allows you to configure the communications options.

The following Communication options can be configured:

Setting	Description
IP Address Range: LAN Specific Default: 010.000.000.015	This allows you to assign an IP address to the SmartDate X60. Always consult your IT department before configuring an IP address.
IP Subnet Mask Range: LAN Specific Default: 255.255.255.000	This allows you to define the Subnet Mask for your specific LAN
IP Gateway Range: As required Default: 010.000.000.001	This allows you to define the IP Gateway for your specific LAN
DCP Actor Name Range: As required Default: Actor 1	This allows you to assign a suitable Actor name as required when using DCP. Re-power required after adding or changing the actor name.
Serial Port 1 Function Range: NGPCL (RS-232) Default: NGPCL	This allows you to select the communication protocol required for Serial Port 1.
Serial Port 1 Baud Range: 9600, 19200, 38400, 57600, 115000 Default: 9600	This allows you to set the Baud rate for Serial port 1.
RS-232 Character Set Range: ASCII or Unicode Default: ASCII	This allows you to select the character set required for RS-232 communication.

Printer configuration

▣ Speed Profile Recorder

This is a Continuous printer feature.

The Speed Profile Recorder allows you to configure the Speed Profile feature options.

The following Speed Profile options can be configured:

Setting	Description
Resolution Range: 1ms, 5ms, 10ms, 50ms or 100ms Default: 1ms	This allows you to define the resolution for the speed profile. i.e. How often the speed is sampled.
Trigger Range: Manual trigger, Print Go trigger or Fault trigger. Default: Manual trigger	This allows you to define the trigger to start the profile.



Printer configuration

▣ NGPCL

(Next Generation Print Communication Language)

This is Markem-Imaje protocol for communicating with devices.

This can be used select products from the local database, update variable data fields on the image etc.

Where fields on the image template are updated on a regular basis, it may be necessary to limit the length of the field names and field data.

The NGPCL menu allows you to configure the lengths of data strings.

For full details regarding NGPCL please contact your local Markem-Imaje office or representative for detailed documentation.

The following NGPCL options can be configured:

Setting	Description
Field Name Length Range: 0 to 100 Default: 0	This allows you to define the length of the field name string.
Field Data Length Range: 0 to 100 Default: 0	This allows you to define the length of the field data string.
NGPCL Success Request Field Range: Yes or No Default: Yes	This is used with NGPCL to control the content of responses.
NGPCL Checksum Enabled Range: Yes or No Default: No	This is used with NGPCL to enable or disable the Checksum option.

Printer configuration

▣ Master / Slave

The Master / Slave function allows up to four additional SmartDate X60 printers to be controlled from a single Master SmartDate X60.

Once the Slave printers are configured, a Job selected on the Master will also be selected on the Slave printers.

Setting	Description
Number of Slaves Range: 0 or 4 Default: 0	This allows you to set a second SmartDate printer to be controlled by the master SmartDate
Slave IP Address Range: Input by user Default:000.000.000.000	This allows you to input the IP address of the Slave printer
Synchronise Start/Stop Range: Yes or No Default: No	When set to Yes the master printer will automatically activate Producing mode on the Slave when the Start button on the master is pressed.

▣ Logging

The Logging menu allows you to configure the Log file options.

The following Logging options can be configured:

Setting	Description
Variable Data Log Level Range: Job Selection/Update, Per Print or None Default: Job Selection/Update	This allows you to define what is logged in the variable data log.
Data Log Full Action Range: Stop Logging Delete Old Data or Stop Printing Default: Stop Logging	This allows you to define what action will be taken if the log becomes full.
Event Log Level Range: Full, Warnings Faults and Information or Faults and Information Default: Full	This allows you to define which data you require for logging.



Printer configuration

▣ SSCC

This feature allows you to configure the Serial Shipping Container Code parameters.

Setting	Description
SSCC Company ID Range: 1 - 16 digits Default: 1	This allows you to enter the allocated Company ID code.
SSCC Current Reference Value Range: 1 - 16 digits Default: 1	This allows you to define the current serial number to be used.
SSCC Minimum Serial Reference Value Range: 1 - 16 Default:	This allows you to define the start value of the incremental number section of the code.
SSCC Maximum Serial Reference Value Range: 1 - 16 digits Default: 1	This allows you to define the end value of the incremental number section of the code.
SSCC Extension Digit Range: 0 - 1 Default: 0	This allows you to define the SSCC extension digit.

▣ External

The External menu allows system Integrators to store information.

Setting	Description
General Purpose 1 to 12	The External menu allows system Integrators to store information.

■ Display Settings

The Display Settings menu allows you to configure the settings of the User Interface Screen.

1

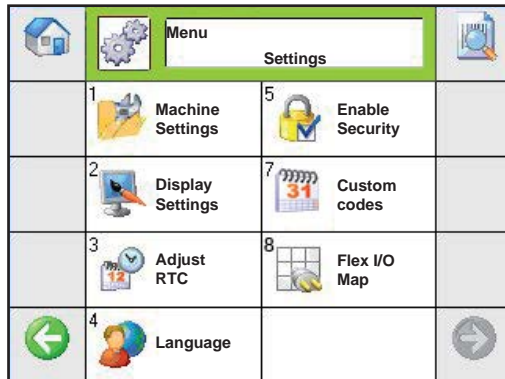

From the Settings screen select Display Settings. .

If an Access Code is prompted for enter the code.

2



The Display Settings screen is displayed.

The following Display options can be configured:

Setting	Description
Calibrate Touch Screen	This allows you to calibrate the user Interface screen.
Print Preview Rotation	This allows you to rotate the preview of the image being printed.
Warning Message Behaviour	This allows you to define how Warning messages are displayed.

Printer configuration

■ Adjust RTC (Real Time Clock)

The Adjust RTC menu allows you to configure the machine internal clock Date and Time settings.

The following Adjust RTC settings can be configured.

1



From the Settings screen select Adjust RTC.

If an Access Code is prompted for enter the code.

2

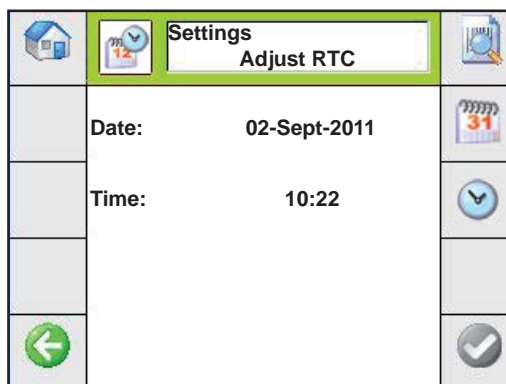

The Adjust RTC screen is displayed.

Setting

Description

Date

This allows you to configure the Date setting for the machine Internal clock.

Time

This allows you to configure the Time setting for the machine Internal clock.

■ Language

The Language menu allows you to select the User Interface screen language. The following Language options can be selected as standard:

Setting

English

Français

Dansk

Deutsch

Nederlands

Español

Italiano

Additional languages are also available. For further information, please contact your local Markem-Imaje representative.



Printer configuration

■ Security

The Security menu allows you to activate or deactivate the password option.

▣ User accounts

The User Accounts menu allows you to configure Individual accounts.
The following User Accounts options can be configured:

Setting	Description
Operator	
Supervisor	
Installation engineer	

■ Time/Date Codes

The Time/Date Codes menus allow you to configure customer specific time and date settings.

The following Time/Date code options can be configured:

Setting	Description
Custom Codes	
Shift Codes	

Settings Custom Codes	
Day of week	Day of month
Sunday	07
Monday	01
Tuesday	02
Wednesday	03
Thursday	04
Friday	05
Saturday	06

■ Flexible I/O Map

This allows you to use the standard settings (Off) or to select a pre-configured (Default) Flex I/O map. The Default can be re-configured to suit customer requirements. For further information please consult the Flex I/O documentation on the CD.

Printer configuration

■ Diagnostics

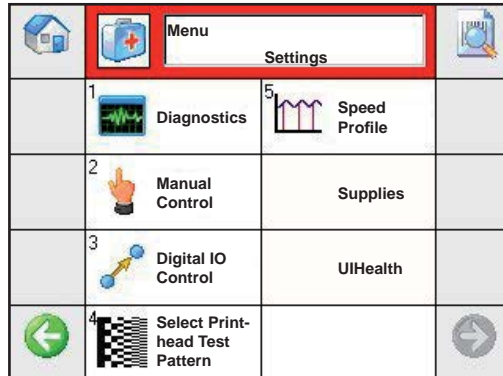

▣ Diagnostics

The Diagnostics menus allow you to view various information about the status of the printer.

For full details see the Diagnostics section

■ Statistics

The Statistics menu allows you to view details about the printers performance.

For full details see the History section

■ Files

The Files menus allow you to organise your file structure.
The following File options can be accessed:

State	Description
Copy Files	Copy files to or from a USB memory stick.
Delete Files	Delete specific files from the job database.
Clear Job Database	Delete all files from the job database.
File Statistics	View information about the files.
Copy Logs to USB	Copy Log files to a USB memory stick.

■ Service

The Service menus allow you to configure various options for your SmartDate.
The following File options can be accessed:

State	Description
Setup Wizard	This will help guide you through the basic configuration for your printer.
Installation Setup	Configure the printhead resistance setting.
Restore to Factory	Re-configure the machine back to the factory default settings.
Upgrade from USB	This allows you to upload the latest version of firmware for your printer.
Suppress Warnings	This allows you select any warnings that you do not want to be displayed.

Printer configuration

■ Version Information

The Version Information menu allows you to view information about the machine. The following Information can be can accessed:

State	Description
Controller Software Version	
Controller Hardware Serial Number	
Language File Version	
Controller PLD Version	
Controller MAC Address	
Controller PCB Version	
Printer Software Version	
Printer Hardware Serial Number	
Printer PCB Version	
FUU Software Version	
Printer Processor Revision	
Controller UI Version	

Diagnostics



Diagnostics



■ Introduction

This section describes the Diagnostics features of the SmartDate X60.

Topics covered in this section include:

- Diagnostics
- Manual control
- Digital I/O control
- The printhead test pattern
- Speed profiles
- Supplies
- Health



Diagnostics

■ Diagnostics

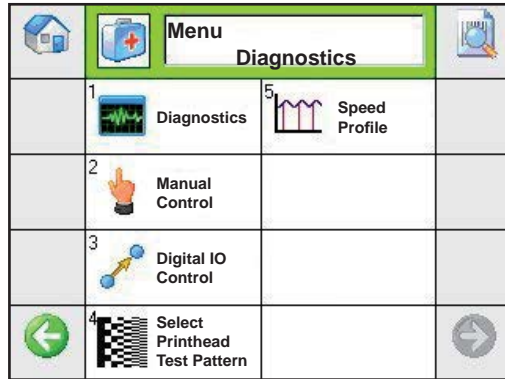

□ Diagnostics

The Diagnostics menus allow you to view various information about the status of the printer.

The following Diagnostics information can be viewed:

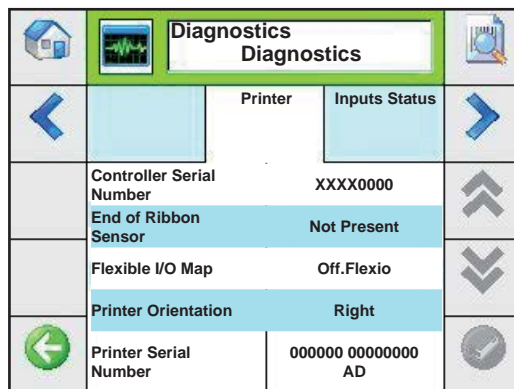

▣ Printer

The Printer Configuration menu allows you to view information that is specific to the individual printer.

The following Printer Configuration information can be viewed:

Setting	Description
Controller Serial Number	Controller specific
End of Ribbon Sensor	Present or Not Present
Flexible I/O Map	Off.flex IO or name specific
Printer Orientation	Left or Right
Printer Serial Number	Printer specific
Printer Type	Intermittent or Continuous
Printhead Technology	Genuine or Non Markem-Imaje printhead width
Printhead Width	Width in mm



Diagnostics

▣ Inputs Status

The Inputs Status menu allows you to view the current status of the printer Inputs. The following Input Status information can be viewed:

Setting	Description
Print Go State	Active or Inactive
Input 1 State Substrate Speed (Continuous)	Active or Inactive Substrate Speed
Current Substrate Speed	Continuous printer only

▣ Outputs Status

The Outputs Status menu allows you to view the current status of the printer Outputs. The following Outputs Status information can be viewed:

Setting	Description
Fault Output State	Active or Inactive
Output 1 State	Active or Inactive
Output 2 State	Active or Inactive
Warning Output State	Active or Inactive

▣ Temperatures

The Temperatures menus allow you to view the current temperatures of the machine. The following Temperatures information can be viewed:

Setting	Description
Controller Temperature	°C
Printer Temperature	°C
Print head Temperature	°C

▣ Print Timing

The Print Timing menus allow you to view information about the individual timings for one print cycle of the currently selected image. The following print Timing information can be viewed:

Setting	Description
Image Update Time	The time taken to update any variable fields on the current image. E.G. Time/Date fields
Imaging Time	The time taken to initiate the image when first selected
Print Cycle Time	The time taken for a complete print cycle, including the time to move the printhead
Printing Time	The time to complete the actual print



Diagnostics

▣ Ribbon

The Ribbon menu allow you to view information about the ribbon currently being used on the printer.

The following Ribbon information can be viewed:

Setting	Description
Remaining prints	hours / mins
Remaining time	hours / mins
Ribbon thickness	um
Supply diameter	mm
Take up diameter	mm
Ribbon core diameter	mm
Ribbon supply length	mm



▣ Internal

The Internal menus allow you to view information about the printer's internal sensors and switches.

The following Internal information can be viewed:

Setting	Description
Printer hours on	Hours
Dead printhead dots	Numeric value
Tension Controller Position	Numeric value
Cassette Switch State	Active or Inactive
Encoder Input A State	Active or Inactive
Encoder Input B State	Active or Inactive
Generic 1	Numeric value
Generic 2	Numeric value
Generic 3	Numeric value
Generic 4	Numeric value
Generic 5	Numeric value
Keypad	Numeric value



Diagnostics

Setting	Description
Left Limit Switch State	Active or Inactive
Motor Voltage	Volts dc
Print Head Voltage	Volts dc
Printer Board Links	Numeric value
Printer Internal Fuse	OK or Fault
Printer Supply Fuse	OK or Fault
Print Head Resistance	Numeric value
Movement Sensor Value	Numeric value

NOTE: *The tension sensor reading.
When in 'Producing' mode the sensor shows the average tension sensor value obtained between prints.
When not in 'Producing' the value is the raw tension sensor value.*

Manual Control

The Manual Control menus allow you to test various functions of the printer. The following Manual functions can be tested:

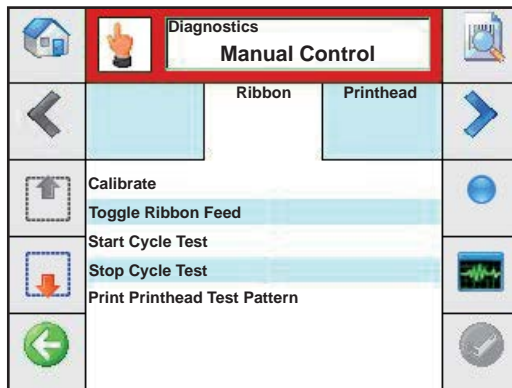

Diagnostics

▣ Ribbon

Function	Description
Calibrate	Activates the Calibration sequence.
Toggle Ribbon Feed	Activates or De-activates the Ribbon Feed sequence.
Start Cycle Test	Starts the Print Cycle
Stop Cycle Test	Stops the Print Cycle
Print Markem-Image Test Pattern	Selects and automatically prints the Test pattern

▣ Printhead

Setting	Description
Head Home (Intermittent only)	Activates the Head Home sequence.
Toggle Solenoid Power	Activates the Printhead prime solenoid with the cassette removed. This allows better access to set the printhead gap.
Toggle Printhead In/Out	Activates or De-activates the Printhead In/Out solenoid.
Toggle Printhead Prime	Activates or De-activates the Printhead Prime position solenoid.

■ Digital IO Control

The Digital IO Control menu allows you to Toggle this various Digital Outputs. The following Digital Outputs can be toggled:

Function	Description
Toggle Fault Output	Activates or De-activates the Output.
Toggle Warning Output	Activates or De-activates the Output.
Toggle User Configurable Output 1	Activates or De-activates the Output.
Toggle User Configurable Output 2	Activates or De-activates the Output.

■ Select Test Pattern

The Select Test Pattern option allows you to replace the currently selected image with the Markem-Imaje Test Image.

■ Speed Profile

This function is used with Continuous printers.

Speed profiles allow the user to assess if the print signal is being activated at the appropriate time.

The running speed of Continuous motion packaging machines will increase and decrease as the substrate is being run through.

In some cases the substrate speed may be faster than the fastest print speed of the SmartDate X60.

If the Print signal is activated at this point in the cycle the resulting print will be unacceptable.

To avoid this problem, the print signal should be activated when the substrate is running at a lower speed.

Creating a “Speed Profile” allows the user to view the exact point in the cycle that the Print Go signal is activated.

If this is at the wrong point, the timing of the Print Go signal can be altered to coincide with a slower substrate speed.

SmartDate X60 provides a new screen intended to help capture and display speed profiles. Once captured, these profiles can be saved to a USB stick for further analysis. The following information details how to use this screen and interpret the graphs it displays.

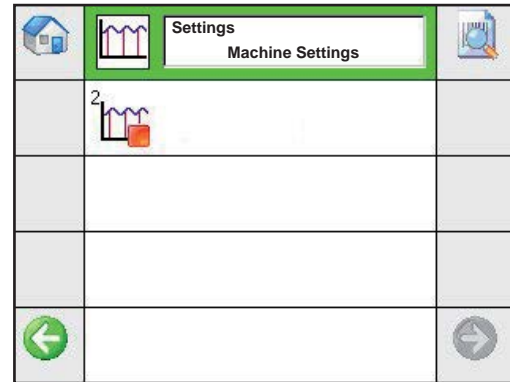
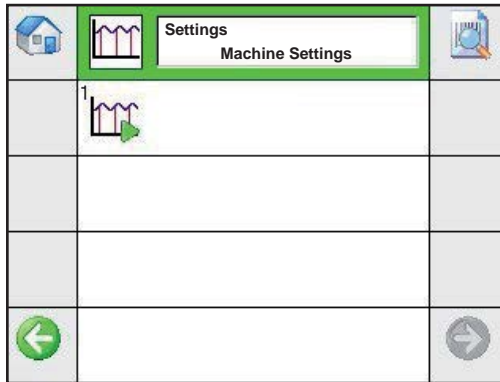

Function	Description
1) Start Speed Profile	Activates the speed profile recorder.
2) Stop Speed Profile	De-activates speed profile recorder.

Start recording now: When pressed, the screen will open and display a please wait message. The printer will immediately begin recording the current substrate speed – the graph will be displayed once sufficient values have been captured.

Trigger recording on print go: When pressed, the screen will open and display a please wait message. The printer will begin recording on receipt of a valid print go signal. The graph will be displayed once sufficient values have been captured.

Start recording – stop on fault: When pressed, the screen will open and display a please wait message. The printer will begin recording immediately and stop only when a printer fault occurs. The graph will be displayed once sufficient values have been captured.

View previously recorded graph: When pressed, the screen will immediately open and display the previously recorded speed profile graph. This option is only displayed if an existing profile has been captured.

Note: when Trigger recording on print go and Start recording – Stop on fault are selected, it is not necessary to remain on the screen and wait for the profile capture to complete. Recording will still continue in the background if you leave the screen. This may be a sensible or necessary option when (eg) you wish to record a fault that only sporadically occurs.

Diagnostics

▣ Interpreting the graph

Assuming you decide to wait for the capture process to complete, a graph will be automatically displayed on screen. The following diagram shows how to interpret details within the graph.

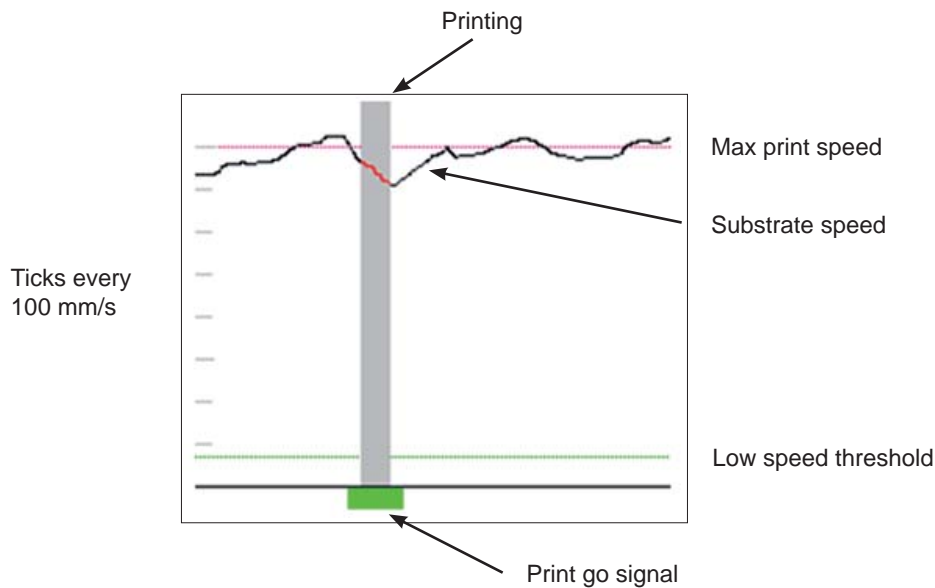

Print-go signals are displayed as green blocks beneath the X axis while the substrate speed is shown above. Note – this is the raw activity level of the print-go signal and may not relate to a print if it is rejected due to debouncing or the print-go ignore function. The period for which the SmartDate is actively printing (ie. the from the first to last printed dot) is displayed as a vertical grey bar.

Tick marks up the side of the graph are placed every 100 mm/s.

Important substrate speed thresholds are shown as horizontal lines:

- A dotted green line defines the low speed threshold - as defined in the system's settings.
- When relevant to the current print mode, a dotted orange line defines the high speed threshold.
- A dotted red line defines the maximum print speed – as defined by the print mode setting.

Examination of this graph should allow you to optimise when the system prints so that printing occurs at an appropriate substrate speed that is stable.

Zooming in on individual prints.

In some cases, it may be necessary to zoom in and examine a single print in more detail. This can be achieved by pressing button 2. When pressed, the screen will zoom in on the leading edge of each print signal in turn. When focussed on the final print go signal, pressing the button will cause the screen to zoom back out to display the entire profile.

Re-recording a profile.

If you want to record a new profile, press button 1. A please wait.. message will appear to indicate the printer is actively capturing information. Once all the information is available to display the graph, the screen will automatically refresh. If you want to cancel this action, simply press the same button.

Copying the profile to USB stick.

If you wish to copy the speed profile to a log file, press button 3. This will save the profile in as a comma-separated value file which can be opened in (eg) Microsoft Excel.



Viewing Information about the profile.

An additional screen is provided to view information about the speed profile as text – accessed from button 5.

Items related to the substrate speed are as follows:

- Maximum print speed. This is the maximum speed recorded during actual printing; ie gray portions of the graph.
- Minimum print speed. This is the minimum print speed recorded during actual printing.
- Average print speed. This is the overall average speed recorded during actual printing.

Items related to the print-go signal are as follows:

- Maximum print go duration. This is the maximum duration of a print-go signal, measured in milliseconds.
- Minimum print go duration. This is the minimum print speed recorded during actual printing.
- Average print go duration. This is the overall average speed recorded during actual printing.

Maintenance



Maintenance



■ Introduction

The SmartDate series of Overprinters are extremely successful, however as with any machine, if it is not set up and maintained correctly, problems can occur.

This section is designed to provide information about how to keep your SmartDate 5 in good working order.

- Topics covered in this section include:
- General cleaning and care.
- Maintenance schemes.
- Care of the printhead.
- Replacing the printhead.
- Replacing the ribbon guide rollers.
- Replacing the peel roller.
- Replacing the ribbon movement roller.
- Replacing the ribbon tension roller.
- Replacing the drive belt.

■ Cleaning and Care

To ensure that your SmartDate X60 operates correctly, the entire unit should be cleaned on a regular basis.

Printer:

Particular attention should be given to the inside of the printer body, especially if food products are able to fall into the unit.

- Turn off the power to the controller.
- Turn off and isolate the air supply to the printer body.
- Remove the printer cassette and clean inside the printer body. Since there are electronic components inside this casing, DO NOT use water to clean the unit. Isopropanol cleaning wipes can be used for this purpose.
- To clean debris from the inside of the printer body, Markem-Imaje recommend the use of a soft bristle brush.



■ Maintenance Scheme

These recommended actions will ensure consistent high quality from the Markem-Imaje SmartDate X60 technology for package identification.

▣ Quick/Regular Checks

- Check and clean printhead (daily check). Use Isopropanol wipes.
- Check that the ribbon is tracking through the cassette correctly. Pull the ribbon through by hand, and visually check to see if the ribbon is creasing across the width of the ribbon. (See Troubleshooting 5.7.3)
- Check the Peel Roller for any ink build up and clean if necessary. Use Isopropanol wipes
- Check that Darkness / Speed settings are site standard. This will ensure that the print remains a good quality, and it may also highlight any potential problems. For example, if the darkness is unusually high, the printhead may need cleaning. The darkness has probably been set high to compensate.
- Check Air is set to recommended pressure.
- Check condition of Platen rubber (SmartDate X60 - Intermittent printer). Clean or replace it if necessary. The platen rubber needs to be smooth, flat and free from debris. - To change the platen rubber, first take the old platen rubber off. All the adhesive should be removed from the metal platen base. Replace with a Markem-Imaje platen rubber for best results.
- Check for wear or internal debris.
- The 37 way D-type cable must be fitted in a manner so that a tool is required to remove it. The unit should not be powered until it is securely attached to each unit.



▣ Monthly Checks

- Check condition of peel roller: Remove roller and inspect internally for wear. Replace if necessary.
- Check condition of the ribbon guide rollers: Check that bearings are smooth.
- Check condition of ribbon sensor roller. Inspect the roller coating for wear and damage. If worn or damaged, replace the roller.
- Ensure all rollers are square to the Cassette or Printer.
- Check the magnet for any damage or non-alignment. This magnet is used for ribbon detection and ribbon calibration.
- Print a test image to check printhead quality and alignment. See Section 6 - Menus.
- Check condition of printhead carriage drive belt and associated components: pulleys, bearings, retainers and shafts.
- Check Air cylinder.
- Check that the tension roller slide is free to move.

▣ Care of the Printhead

Although purpose-built for its application, the printhead is still subject to wear and tear. Careful consideration at the time of installation and regular preventative maintenance can significantly help to maximise printhead life.

The most frequent cause of printhead damage is abrasion - either from ingress of airborne particles or from an abrasive substrate surface. Consequently, printhead life varies considerably among substrate materials and among applications.

The thermal ribbon protects the printhead against wear. With use of various ribbon widths and an abrasive substrate, it is possible that the unused, unprotected, section of the printhead is subjected to wear and damage. Usually, abrasive substrates have pre-printed inks. Particularly, some red inks may be more abrasive than other colours.

Procedures for all thermal transfer printers follow:

- Regularly clean the printhead. The frequency of cleaning is entirely application and environment specific.
- To minimise printhead wear, always use the minimum air pressure that delivers an acceptable print quality. Never exceed the maximum air pressure recommended for the particular SmartDate X60 used.
- Use the minimum darkness setting that delivers the required print quality.



■ Cleaning the Printhead

The printhead should be cleaned at regular intervals. These depend on machine use, operating environment, and choice of thermal ribbon.

- 1 Turn off the power to the controller and remove the ribbon cassette. Allow the printhead to cool to normal room temperature before proceeding in order to prevent the possibility of thermal shock damage.

2

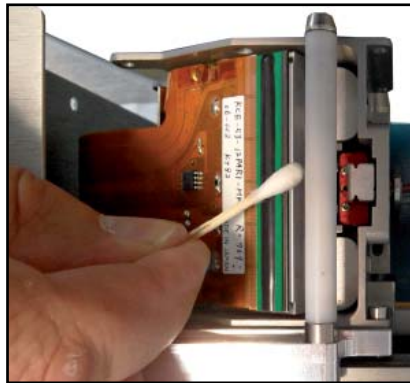

Use a cotton swab or a soft cloth soaked in Isopropanol solvent to remove any residue from the printhead. Take care not to use excessive amounts of solvent.

The print line is located on the bevelled edge of the printhead.



Use great care not to damage the printhead during cleaning. **UNDER NO CIRCUMSTANCES** should abrasive materials, or tools such as screwdrivers, be used for cleaning the printhead.

Replace the ribbon cassette and check the print quality. If the overall quality is poor, or some of the dots are not printing, the printhead may need to be adjusted or changed.

■ Replacing the Printhead

The SmartDate X60 printhead can be changed quickly and easily.
Turn off the power to the controller and isolate the air supply to the printer body.
Remove the ribbon cassette.
Always ensure anti static precautions are used when handling new printheads.

▣ Removing the damaged printhead (Combined)

1

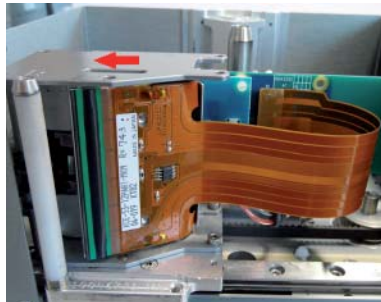

Push the printhead forward towards the peel roller and rotate the rear of the printhead outwards as shown above.

2

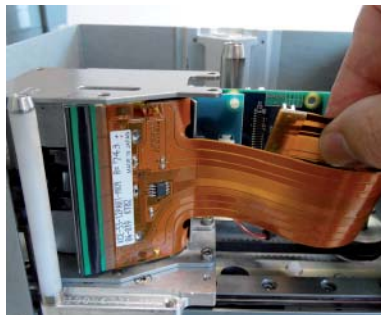

Disconnect the ribbon cable from the printer interconnection PCB.

3

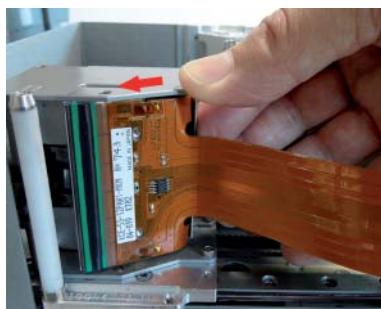

Push the printhead forward towards the peel roller and rotate the rear of the printhead outwards as shown above.

Maintenance

4



Swing the printhead out from the print module.

5

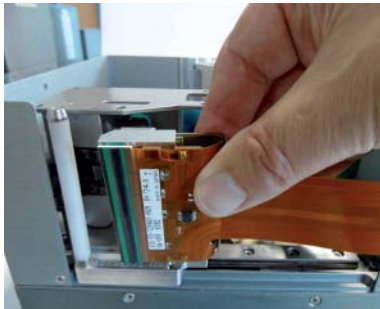

Remove the printhead from the print module.

6

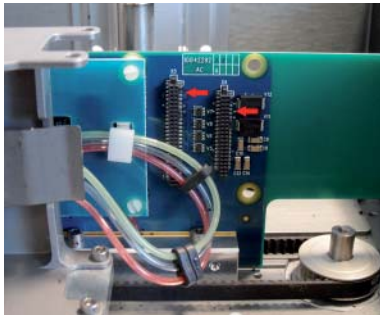

Note the different connectors:
X5 Smarthead
X4 Standard Head

▣ Removing the damaged printhead (Shuttle)

1

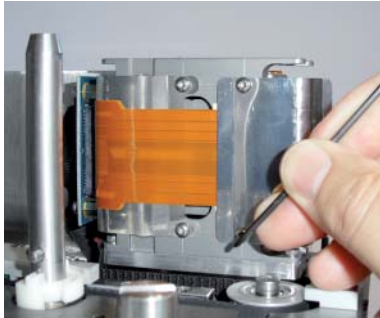

Remove the retaining screws from the printhead ribbon cable guide.

2

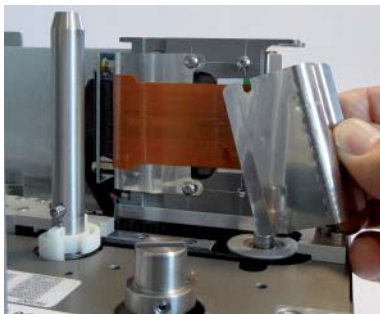

Remove the ribbon cable guide.

3

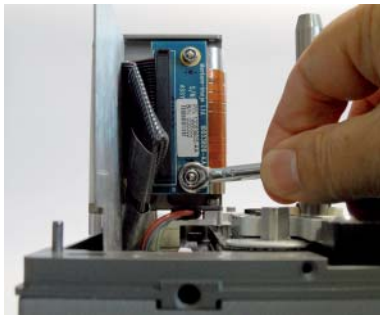

Remove the two retaining screws from the ribbon connector block.

4

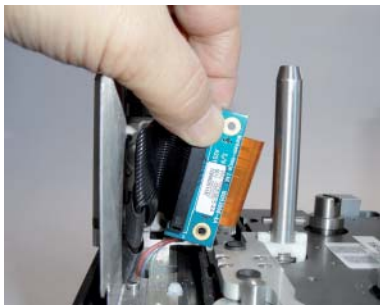

Disconnect the ribbon cable from the PCB.



Maintenance

5



Remove the ribbon cable from the connector.

6

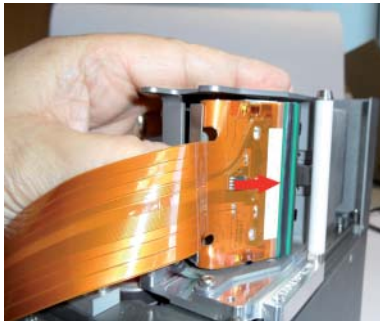

Push the printhead forward towards the peel roller and rotate the rear of the printhead outwards as shown here.

7

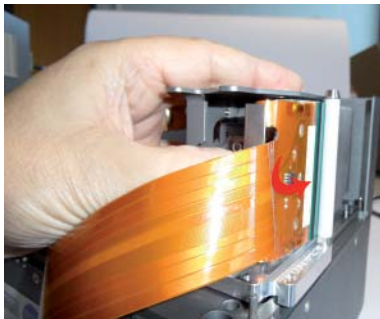

Swing the printhead out from the print module.

8

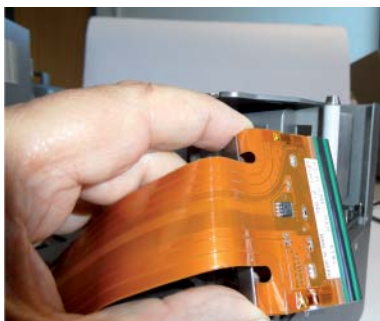

Remove the printhead from the print module.

▣ Setting the correct printhead resistance

NOTE: with Smarthead printheads the resistance setting is automatic.

NOTE: the resistance value is printed on the PCB side of the new Printhead. This value must be entered into the controller menu structure if a non Markem-Imaje printhead is used..

The processor will then adjust the voltage level to suit the particular printhead resistance level.

Each Printhead has an individual Resistance level, and the voltage level setting required for each is different.

A label on the printhead displays the rating for that particular one.

In this case, R = 1272

The Printhead resistance option can be accessed from the Service menus.

The Security must be set to Enabled for the Service options to be displayed.

To access the Service Menu:

Select Menu and enter the appropriate password.

The Menu screen is displayed.

1

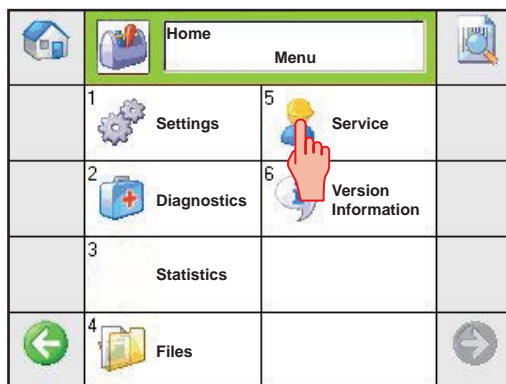

From the Menu screen select Service..



Maintenance

2

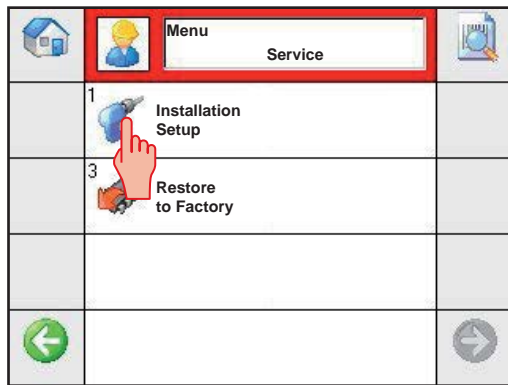

Select Installation Setup.

3

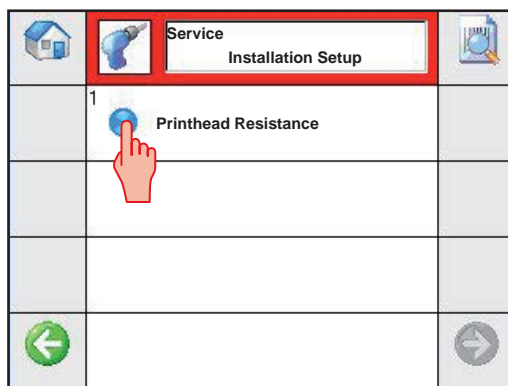

Select Printhead Resistance.

4

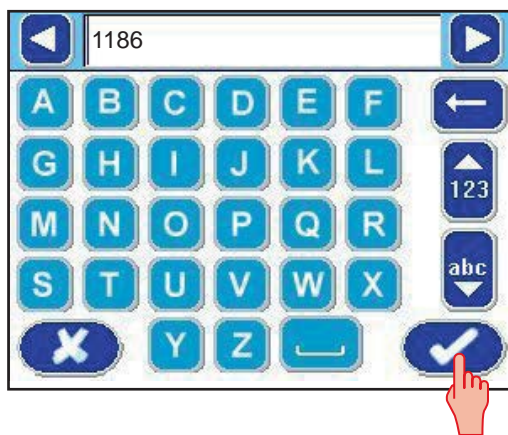

Enter the new value.
When finished press the tick symbol to accept the changes.

■ Replacing the Peel Roller

The Peel Roller body is a wear part and should be checked for damage and changed if necessary..

1

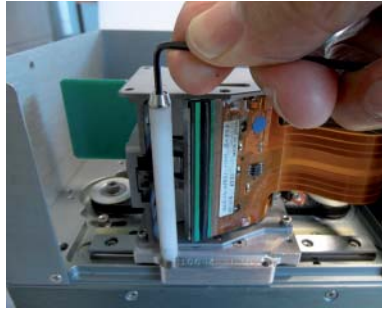

Remove the retaining screw from the end of Peel roller.

2

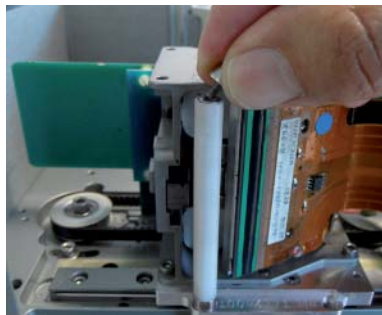

Remove the screw and washer.

3



Lift off the roller body.



Maintenance

4



Fit a new Peel roller body over the shaft and add Loctite 222.

5

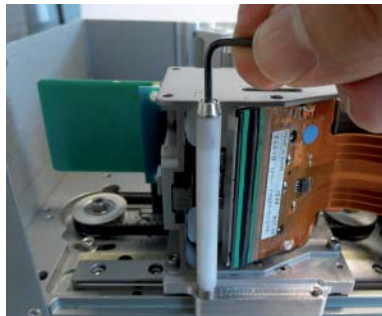

Secure the screw.

6



Clean off any excess fluid and ensure the roller is free to rotate.

Maintenance

1

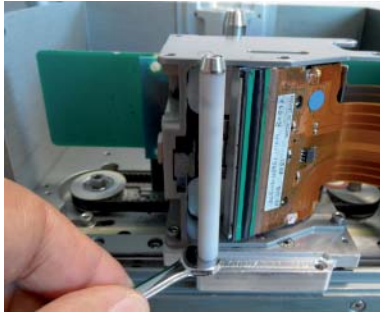

If the peel roller shaft has been damaged, undo the retaining nut at the base and remove the complete assembly.

2

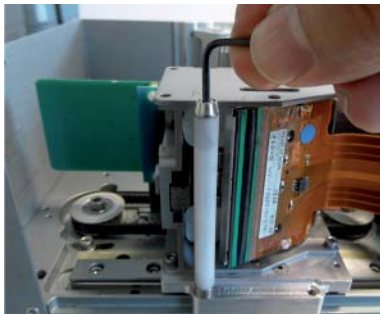

Once the seal has been broken at the base of the screw, use an Allen key to unscrew the Peel roller.

3

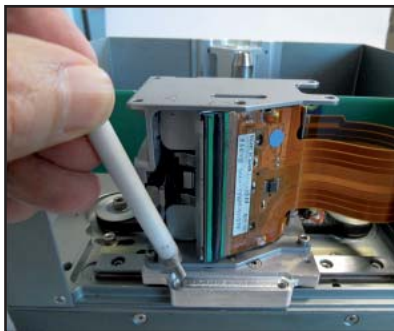

Remove the roller from the printer carriage plate.



Maintenance

4

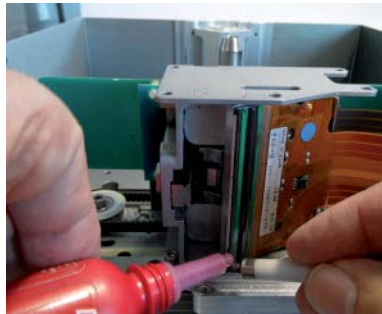

Fit a new peel roller assembly and ensure that it is secure and free to rotate. Secure with Loctite 222.

5

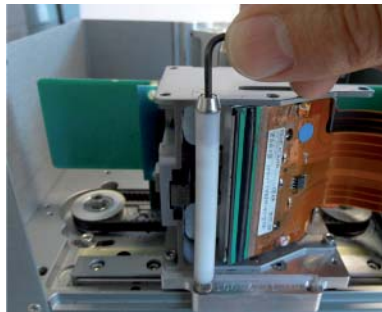

Tighten the screw.

6



Clean off any excess fluid and ensure the roller is free to rotate.

■ Replacing the Ribbon Guide Rollers

The ribbon guide rollers are vulnerable to damage through misuse and may have to be changed if they become bent or damaged.

1



Remove the damaged roller by applying a spanner to the two flat surfaces at the base of the roller.

2



Place the damaged roller to the side.

3



Before fitting a replacement roller, apply Loctite to the screw thread at the base of the roller.



Maintenance

4



Place the new roller in position and tighten.

5



Ensure that the Roller is free to rotate.

6



Clean off any excess fluid and ensure the roller is free to rotate.

■ Replacing the Ribbon Movement Roller

▣ Replacing the Roller Magnet

If the magnet on the movement roller has been damaged it will have to be replaced.

1



Remove the securing screw on the end of the roller.

2



Remove the screw and securing washer.



Maintenance

3



Remove the damaged magnet and rubber washer.

4



Fit a new magnet and rubber washer.

5



Replace the Securing washer and tighten the screw.

▣ Replacing the Movement Roller

The procedure for replacing the ribbon movement roller is the same as for the ribbon guide rollers.

1



Remove the damaged roller by applying a spanner to the two flat surfaces at the base of the roller.

2



Before fitting a replacement roller, apply Loctite 222 to the screw thread at the base of the roller.



Maintenance

3



Place the new roller in position and tighten.

4



Secure the roller in position.



Clean off any excess fluid and ensure the roller is free to rotate.

■ Replacing the Ribbon Tension Roller

If the tension roller becomes damaged the whole assembly will require changing. Dependant on the hand of the cassette the ribbon supply flange (red) may have to be removed to gain access to the securing screws.

1

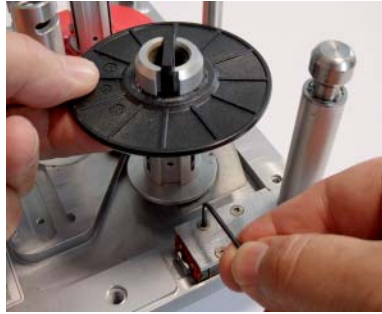

Remove the four retaining screws from the tension roller carriage.

2

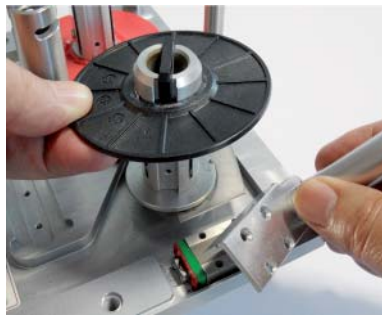

Remove the damaged tension roller assembly.



Maintenance

3



Replace with a new assembly.
Ensure the spring is inserted correctly.

4

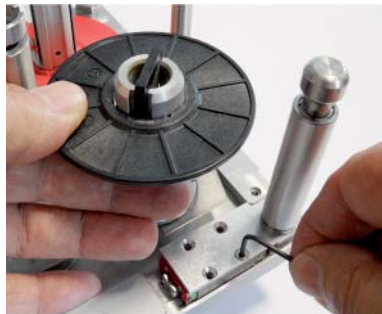

Secure the screws with Loctite 222.

History



History

■ Statistics

The Statistics Menus allow you to view information about the printers producing performance.

To access the Statistics screen select Menu and Statistics.

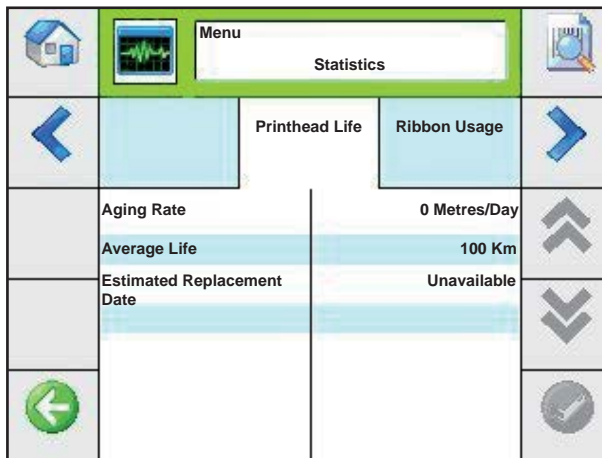
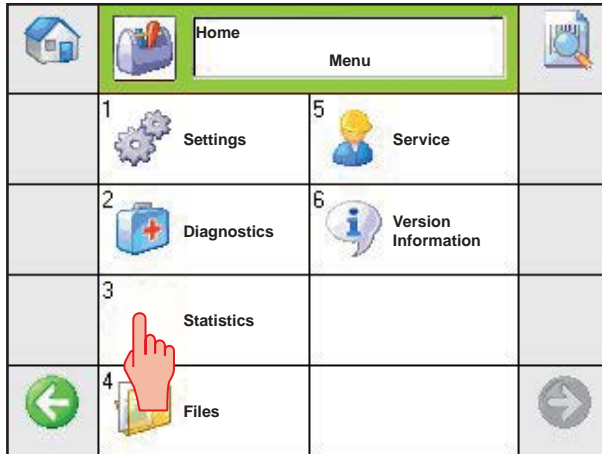

■ Statistical Information

▣ Printhead Life

The following Statistical information can be viewed:

Function	Description
Aging Rate	Metres/Day
Average Life	Km
Estimated Replacement Date	Dependant on usage

▣ Ribbon Usage

Function	Description
Actual Prints on Current Ribbon	Length in km
Actual Prints on Previous Ribbon	Length in km
Ribbon Used for Current Printhead	Length in km
Average Ribbon Change Time	Time in Minutes

▣ Printer Usage

Function	Description
Printheads Fitted	The number of Printheads that have been fitted to the specific printer.
Time Motors have been Running	Time in Hours
Total Print Cycles	Numeric Value

▣

▣ Throughput

Function	Description
Average Print Speed	This is Continuous printer feature.
Instant Average Pack Rate	Packs per minute.
Long Term Average Pack Rate	Packs per minute
Max Print Speed	This is Continuous printer feature.

▣ PackML State Times

The following PackML State Times information can be viewed:

State	Description
Producing	Time in Hours/Minutes/Seconds
Ready	Time in Hours/Minutes/Seconds
Starting	Time in Hours/Minutes/Seconds
Aborted	Time in Hours/Minutes/Seconds
Held	Time in Hours/Minutes/Seconds
Stand-by	Time in Hours/Minutes/Seconds
Aborting	Time in Hours/Minutes/Seconds
Holding	Time in Hours/Minutes/Seconds
Stopping	Time in Hours/Minutes/Seconds
Stopped	Time in Hours/Minutes/Seconds



History

External links



External links

■ Controller and Printer Connection Points

The main connection points for the Controller unit are shown below:

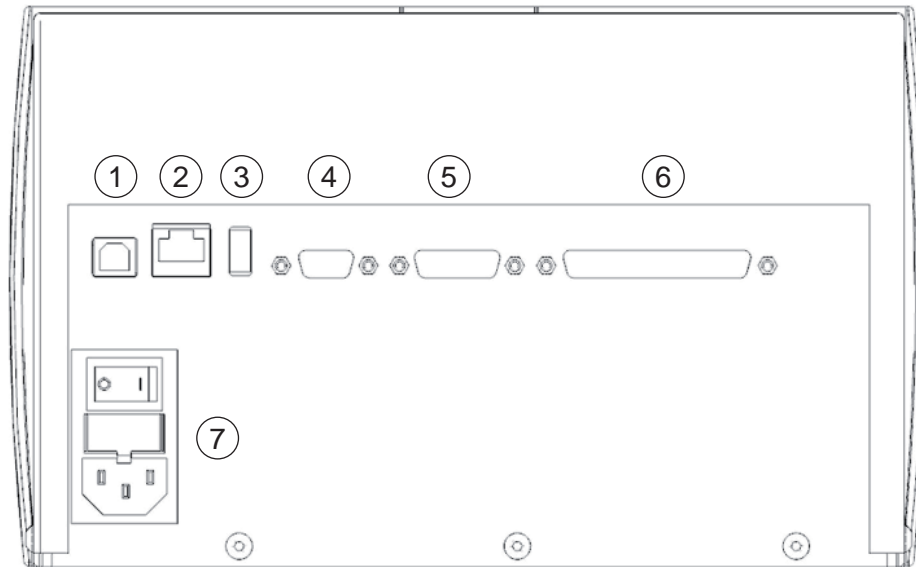

Controller Connection Points (Rear View)

1. USB-B Connector
2. Ethernet Connector.
3. USB-A Connector
4. RS-232 Comms Connector.
5. External I/O Connector.
6. Printer Power / Control Connector.
7. Mains Connector, Fuse and Power Switch.

The D-Type connectors must be fitted such that a tool is required to undo them. At no point should the unit be powered until these are securely attached to each unit.

External links

▣ Printer

The main connection points for the Printer unit are shown below:

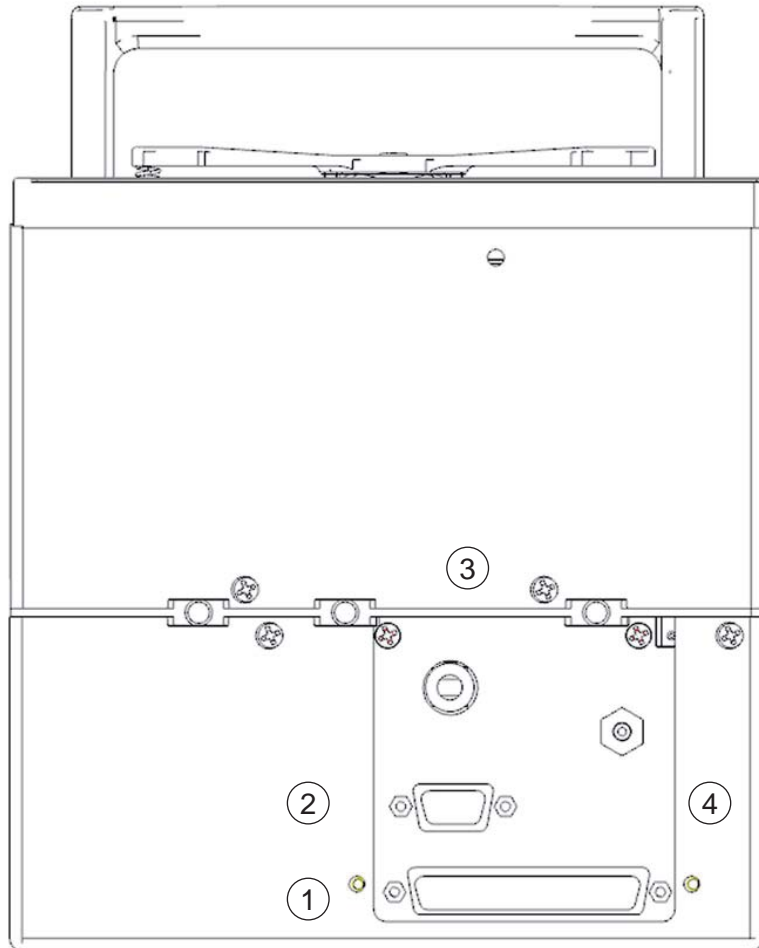

Printer Connection Points

1. Printer Power and Signals.
2. Encoder.
3. Air Inlet.
4. Air Exhaust.

■ Printer Power and Control Signals

A single cable connects the Controller and the Printer Body.

This cable can be up to 10 metres in length.

Both power and signals are present in the single multi-core cable.

To ensure robust signal integrity, the Controller to Printer link is via a twisted-pair RS-422 interface.

The cable is terminated at each end by 37 way D type connectors, one male one female.

The cable must be inserted into Controller and Printer Body and firmly secured prior to switching on the unit.



External links

■ Control I/O Connections

A 15-way cable with a D-type plug connector on the rear of the Controller provides:

- Connection to the PRINT GO input.
- Access to the Fault and Warning Status outputs.
- Access to the User configurable Digital I/O

Pin	Description
1	+24 VDC - I/O
2	PRINT GO Input (PNP sensor or +24V Switched) Controller PCB Link - X11 Position A -PNP
3	0 V - I/O
4	User Configurable Digital Input 1 (PNP sensor or +24V Switched) Controller PCB Link - X12 Position A -PNP
5	Reserved
6	Reserved
7	Fault Output (Contacts Open for Fault)
8	Fault Output (Contacts Open for Fault)
9	Warning Output (Contacts Close on Warning)
10	Warning Output (Contacts Close on Warning)
11	User Configurable Digital Output 1# (24V PNP)
12	0 V - I/O
13	User Configurable Digital Output 2# (24V PNP)
14	Reserved
15	Reserved

Print Go Input Wiring

Print Go Input using a voltage free contact

If a voltage free contact is used it should be wired between terminals 1 (24 V DC) and 2 (PRINT GO). SmartDate 5 is edge triggered and prints whenever the contacts close, but will not print again until the contacts have opened and closed again after printing is complete.

Print Go Input using a PNP sensor

If a PNP sensor is used connect as follows:

- Signal cable into terminal 2 (PRINT GO)
- Ground cable into terminal 3 (GND)
- Power cable to terminal 1 (+24 V)

SmartDate 5 prints each time the sensor changes from low state to high state. The input draws a maximum of 13 mA at 25 VDC.

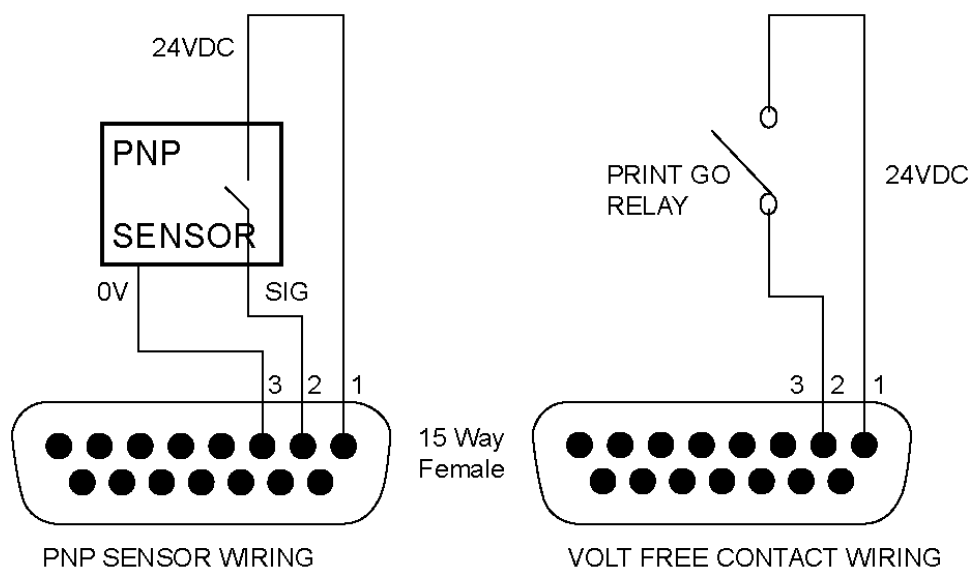

External links

▣ Fault and Warning Outputs

Fault - (Problem)

Pins 7 and 8 on the 15-way connector are the open relay contacts for FAULT.

Fault relay contacts open when SmartDate 5 is:

- In **READY** mode.
- Not in a position to print because of a **PROBLEM**

READY mode:

The Unit OK signal is switched off when the SmartDate 5 is switched out of PRODUCING mode and into **READY** mode.

ABORTED mode: (Fault)

If a problem occurs the SmartDate 5 will automatically switch to **ABORTED** mode and indicate that there is a problem.

PRODUCING mode:

The contact is closed when the printer is ready to print.

The contacts should be used to provide an interlock to the overall control of the packaging machine.

It is recommended that this signal is always used to prevent unmarked products being produced.

Warning

The Warning relay contacts close when a warning such as a low ribbon condition is detected.

Pins 9 and 10 on the 15-way connector are the closed relay contacts for Warnings.

The contact is open when the printer is ready to print.

The relay contacts are suitable for a current between 10mA and 1A. The maximum rating is 1A at 30VAC/DC. Control of higher voltages (e.g. 100VAC) or currents must use intermediate external control relays or contactors.



■ Encoders

For continuous printers, an encoder is required to monitor the speed of the substrate. It is essential that the encoder measures the speed of the substrate at the point of printing.

The encoder should be mounted so that the wheel of the encoder is running against the print roller.

Markem.Imaje recommend that a Quadrature encoder is used.

This measures the substrate movement in both directions (forwards and backwards) ensuring that any backward drift when the packaging machine is stopped is accounted for. The Encoder setup can be configured from the Engineering Mode Settings menu screen.

SmartDate 5 requires the encoder to provide:

- Between 2.8 - 150 pulses per mm of substrate travel.
- The output connects to an NPN open collector output, operating at 24 V DC.
- The standard SmartDate 5 encoder is 500 pulses per rev. with a 52.5 mm tracking wheel, giving a resolution of 3.05 pulses/min. (The printer default setting)

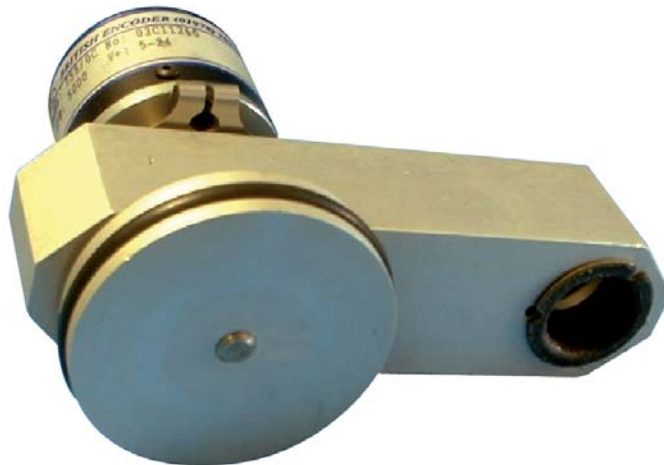

A high resolution encoder (5000 pulses/rev) should be used where print speeds lower than 70mm/s are experienced during the print cycle. This is also the case if the packaging machine exhibits high acceleration from low speeds.

With images that are longer than 50mm the encoder must be re-calibrated.

External links

▣ Quadrature Encoders

A quadrature encoder has two electrical channels that allow it to report distance / speed and direction. This is the preferred type of encoder in that it allows the SmartDate 5 to take care of any changes in direction.

Encoder Direction

When using a quadrature encoder it is important that the SmartDate 5 is aware of the normal operating direction.

When used with an Idler wheel the setting will define the direction of the encoder wheel (Clockwise or Anti - clockwise) when viewed towards the encoder wheel when the machine is printing normally.

This can be validated by viewing the substrate speed on the Diagnostics screen inputs. An incorrect setting will display a negative speed value.

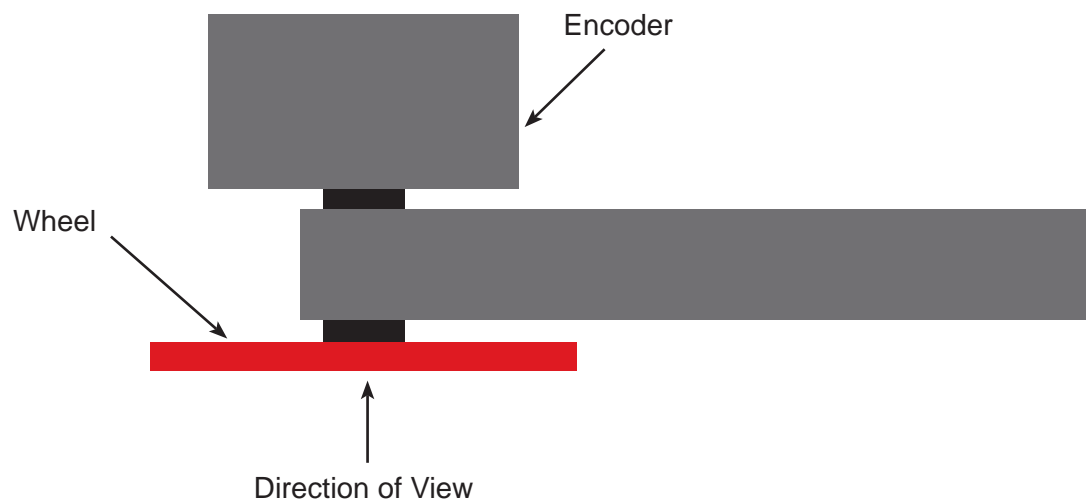

For details of the pin connections please refer to Section Electrical Schematics.

▣ Encoder Resolution

The encoder resolution is expressed in stripes (pulses) per mm and can be set to between 2.8 stripes / mm and 150 stripes / mm.

The standard SmartDate 5 encoder has an idler wheel of 52.5 mm mounted on a 500 stripes per revolution encoder. This gives an encoder resolution of 3.05 stripes / mm.

Encoder Setup

The idler wheel typically runs on a rubber roller and in the case of the SmartDate 5 has a rubber tyre on the wheel. It is difficult to determine the exact measurements, therefore the following procedure can be used to validate the setting.

1. Create an image containing one horizontal line.
2. Set the SmartDate 5 to fixed spacing mode by setting the Print trigger setting to 3. Internal. (this can be found in the Engineering -Settings menus under Print Initiation)
3. Set the fixed spacing distance to 100 mm or greater.
4. Run the substrate at a constant speed and allow the printer to print a number of prints.
5. Stop the substrate and measure the distance between the leading edges of the two adjacent prints as shown below.
6. The distance should equal the configured fixed spacing distance.
7. If it is more than 0.5 mm out the encoder resolution should be adjusted.

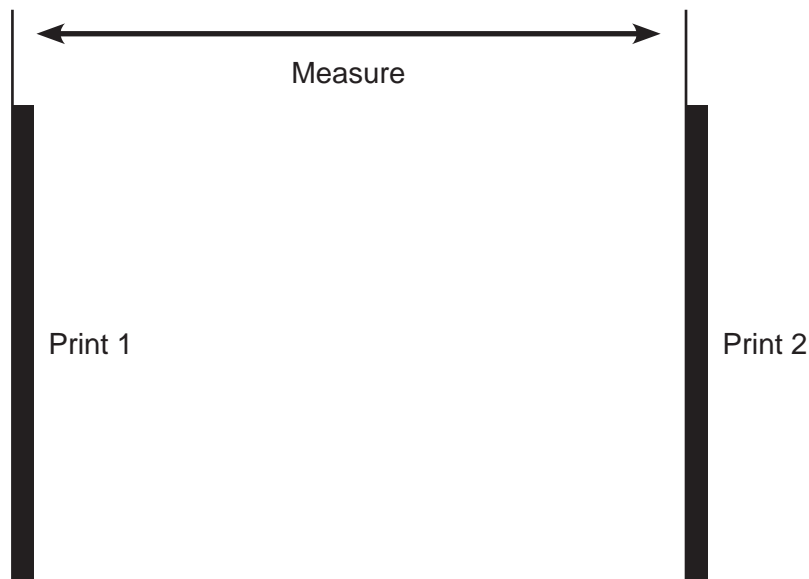

External links

▣ Single Channel Encoders

Single channel encoders can be used with SmartDate 5 continuous printers, but will not be as efficient as quadrature encoders.

The substrate movement is recorded in one direction only, any drift backwards is not accounted for.

The setting for this type of encoder is External - Pulse train. This covers single channel encoders and bagging machines that output a single channel movement signal.

▣ Fixed Speed settings

This setting can be used if the substrate runs at a constant known speed. The setting for this method of running is Internal, and the substrate speed must be manually entered.

With images that are longer than 50mm the encoder must be re calibrated



■ Communication Links

The standard recommended Comms connection for SmartDate 5 is Ethernet.
The method of communication is via Markem.Imaje Device Communication Protocol (DCP)

RS-232 communication is also available but only for use with Markem.Imaje Next Generation Printer Control Language (NGPCL)

This is used for remote selection of Jobs in the local database, updating field data on the image etc.

■ NGPCL Communication

(Next Generation Print Control Language)

NGPCL is a protocol that is used to connect Markem.Imaje NextGen based printers to simple line control equipment.

This equipment is typically PLC based and is not capable of handling more complex message structures such as DCP (Device Communication Protocol)

An example where NGPCL might be used is where a SmartDate 5 is being used to print information that changes from one print to the next.

A check weigh machine could be used to send specific information about the weight of individual packs.

This data would be used to complete the updated field information on the print design.

Another example might be where the line device informs SmartDate 5 to select a specific Job and set an Allocation of 10.

SmartDate 5 would then limit the number of times that the Job was printed to 10.

Printer Status information can also be supplied to the line device.

NGPCL can be connected via RS-232 or Ethernet.

For more information about NGPCL please contact your local Markem.Imaje office or agent.



■ Communication Options

Several communication options are available:
These include the following:

- Ethernet from a PC or Server to a SmartDate 5.
- Ethernet Network from a PC or Server to a series of SmartDate 5 printers.

Controlling SmartDate 5 from a PC

By using CoLOS Control all SmartDate 5 printers can be controlled from a single PC. This allows the user to setup Jobs for the SmartDate 5 printers or configure printers settings from the PC.

Job setup can be done individually or printers can be grouped together to enable several SmartDate 5 printers to be setup at the same time with the same job.

For full details about CoLOS Control please consult the Markem.Imaje CoLOS Control documentation.



Technical specifications



Technical specifications

Machine Specification

SmartDate X60

Specification

Print Area	SmartDate X60 - Combined Intermittent Mode 53 mm x 75 mm SmartDate X60 - Combined Continuous Mode 53 mm x 150 mm SmartDate X60 Shuttle Continuous 53 mm x 100 mm
Substrate Area	Unlimited.
Print Speed	SmartDate X60 -Comined Intermittent printer 70 - 700 mm/s SmartDate X60 -Combined Continuous printer 30 - 1000 mm/s SmartDate X60 -Shuttle Continuous printer 30 - 1000 mm/s
Max Pack Rate	SmartDate X60 - Intermittent Mode 200 ppm with a 10 mm image SmartDate X60 - Continuous Mode 280 ppm with a 10 mm image (148 mm bag)
Printhead Resolution	300 dpi (12 dots/mm).
Printhead Gap	Intermittent Printers - 0.5mm - 5mm (Max) Continuous Printers - 0.5mm - 3mm
Print Method	Thermal Transfer.
Power Supply	~ 100 - 230V (+/- 10%) 50 - 60 Hz
IP Rating	Controller IP 41 Printer IP 2X
Environmental	Operating environment of: 32° F to 104° F(0° C to 40° C)



Technical specifications

Noise Levels	<p>Test Standard BS EN ISO 3746:1996 SmartDate X60 Intermittent printer 199 ppm with a 10 mm Image (700 mm/s) <70 dB (A) SmartDate X60 Continuous printer 299 ppm with a 10 mm Image (160 mm bag) (800 mm/s) 70 dB (A)</p>
Air Supply	6 bar / 90 psi (maximum) dry, uncontaminated.
Air Consumption	<p>Max at 5 bar with 4.0 mm (1.6") printhead gap = 8.8 ml/cycle (0.15 cubic inches/cycle). Typical at 3 bar with 1.5 mm (0.06 ") printhead gap = 2.0 ml/cycle (0.123 cubic inches/cycle)</p>
Printer Dimensions	<p>SmartDate X60 180 mm (7.08") length x 209 mm (8.22") width x 197 mm (7.75") height. Allow a minimum of 100 mm above the printer for extension of the handle and ribbon cassette removal.</p>
Controller Dimensions	<p>195 mm (7.67") length x 255 mm (10.3") width x 115 mm (4.5") Allow a minimum of 80 mm (3.15 ") for the connector and cable access to both printer and controller.</p>
Printer Weight	SmartDate X60 - 7.82 kg
Controller Weight	4.0 kg
Ribbon	<p>Cassette loaded: Maximum ribbon length 1100 metres (3820 Grade) Maximum ribbon width 55 mm Minimum ribbon width 20 mm</p>
Colours	<p>An extensive range of approved Markem-Imaje ribbons are available including Black, White and a selection of other colours. Only Markem-Imaje approved ribbon types must be used to enable / maintain / and sustain the quality / adhesion / performance of the printer.</p>
Font Styles	Any True Type font. + Speedo and TI Corpus Christi
Font Sizes	Scalable to specific point sizes.
Orientation	Any mix of orientation.
Barcodes	Code 39, EAN 8, EAN 13, EAN 128, UPC A and UPC E, RSS-14 QR, RSS-Expanded

Technical specifications

Graphics	Lines, Boxes and Logos (*.bmp format)
Special Functions	Automatic Real Time, Date, Batch and Shift Information. Automatic 'Best Before End' offset calculation and coding. Incremental alphanumeric text and barcodes.
Local SmartDate X60 Memory	20Mb.
Machine Interface	Inputs: 'Print' input signal status. Outputs: Interlock Output User Configurable I/O
Operator Interface	The user interface screen comprises of a colour LCD touchscreen and a four button hot key interface. Wipe Clean touchscreen for a local entry of variable information, complete with Full Diagnostics capability.
Computer Interface	Ethernet
Design Software	Markem-Imaje CoLOS Create Pro for Windows design package, for IBM compatible PC Operation.
Network Software	Markem-Imaje CoLOS Control for Windows network, for data transfer, remote operation and machine monitor / data logging operations, for IBM compatible PC Operation.
Options	Low Power Beacon Lights
USB	USB-B USB-A



Technical specifications

■ SmartDate X60 User Manual - Revision

- . The revision AA index corresponds to the first edition of this manual.
- . The revision index changes with each update.

Date published	Revision index documentation	Software index
11-2011	AA	

For Marking & Coding Equipment. Photographs and drawings are not binding in detail. This document was originally written in English. The English text of this document shall alone be authentic and shall prevail in the event of a dispute. Markem-Imaje reserves the right to modify the specifications of its products without prior notice. Any reproduction, even partial, of this document is prohibited. Original manual:

© 2011 Markem-Imaje All Rights Reserved. English version



