

Auto Splice Dual

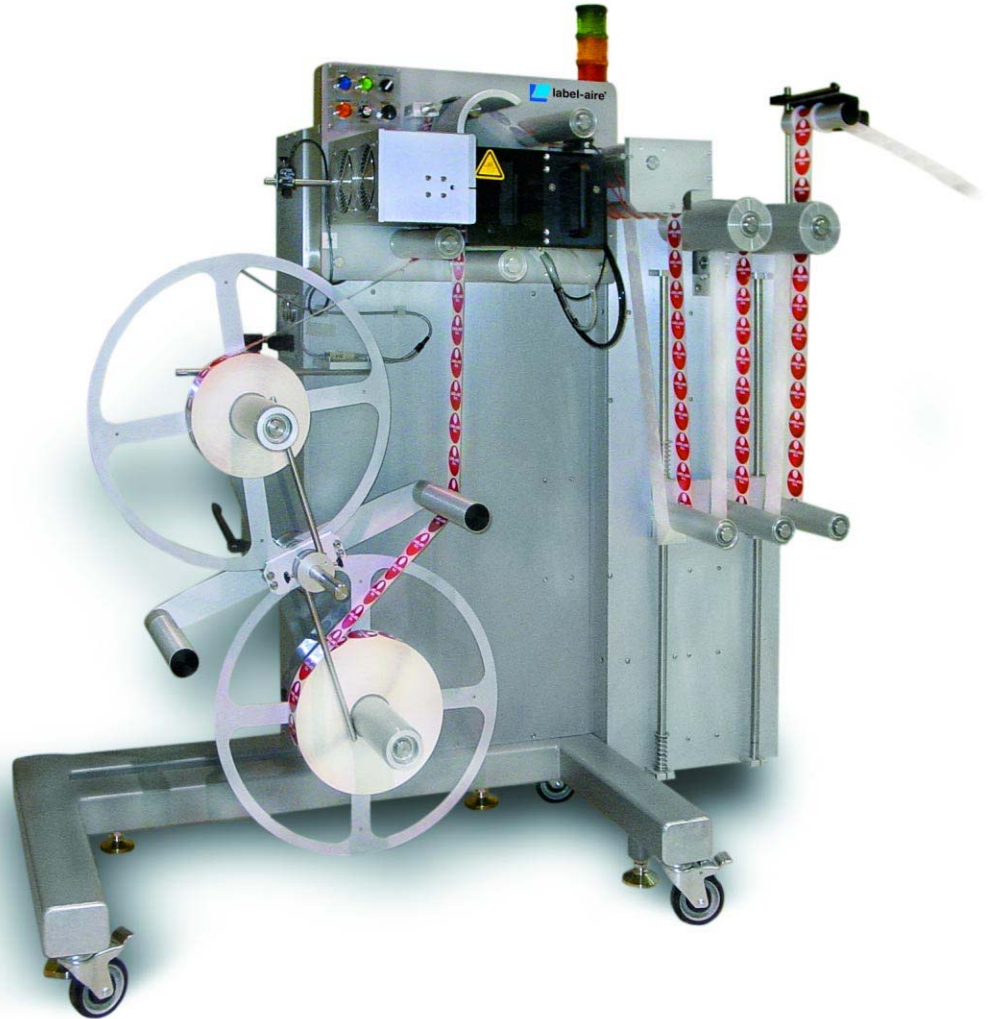

Auto Splice Dual Unwinder With Festoon

Accessory

Unwinder

Auto Splice Dual Unwinder With Festoon Specifications

The Label-Aire® Auto Splice Dual Unwinder with Festoon is engineered to greatly improve your productivity by eliminating time consuming change-overs.

The Label-Aire Auto Splice Dual Unwinder (ASDU) with Festoon is a high-speed servo drive, PLC controlled, continuous feed unit designed to roll up to your production line and improve line efficiency with minimum operator effort. The ASDU with Festoon features speeds up to 5,000 inches (127 m) per minute and comes equipped with dual 20 inches (508 mm) unwinds. The ASDU's label sensor and DC servo ensure tight and accurate label splicing. A variety of label sizes can be handled (for example, promotional and coupon labels) by the ASDU and is compatible with all Label-Aire labelers as well as other brands of labelers.

Roll the Auto splice Dual Unwinder with Festoon up to your production line and immediately increase line efficiency freeing up the operator for other production tasks.

- Festoon provides consistent tensioning of labels throughout system.
- Servo drive provides labels to applicator at labeling demand rate for smoother operation.
- Eliminates stoppages due to roll changes.
- Improves production line efficiency.
- PLC controls with DC servo for tight and reliable automatic splices.
- Automatic splicing maintains registration.
- Dual 20" (508 mm) diameter unwinds and automatic splicing eliminate downtime.

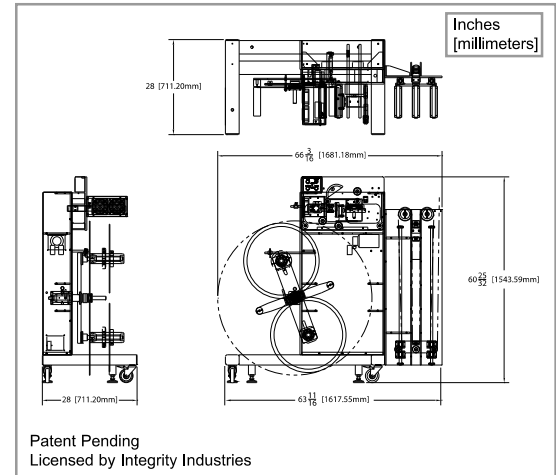

Label Dimensions:

Label Width: 1" (25.4 mm) min. up to 8" (203 mm) depending on application

Label Packaging:

3" (76 mm) core – 20" (508 mm) O.D.

Speed:

Up to 5,000" (127 m) per minute

Electrical:

120/240 Volts +/- 10% 5 Amps

Air:

.5 cu ft (152 cu cm)/splice @ 80 psi

Options:

6" (152 mm) label core adapter
Turn bars for side panel labeling
Clear label sensor kit
230 VAC
Static eliminator
Can be configured to work with Checkpoint and Sensomatic security tags
Right hand or left hand configurations available



QLC

537 Progress Drive
Hartland, WI. 53209
Phone: (262) 367-1400
Fax: (262) 367-1405
Toll Free: (800) 837-1309
Email: info@qlc-labeling.com