



Rotary Series 9000

Labeling System

Rotary Series

9000

Rotary Series 9000

The Label-Aire® **Rotary Series 9000** labeling system has advanced features to make labeling your products easier and faster...making you more profitable.

The Rotary Series 9000's long list of optional features allows you to build a high-speed system to meet your specific labeling requirements. The Rotary Series 9000's toughness, speed, and accuracy translate into lower operating costs and increased productivity for your business.

The rugged yet advanced Rotary Series 9000 was designed specifically for high-speed, high-accuracy labeling applications. It is also easy to install and can operate at speeds up to 600 cpm. Configurations range from 4 to 40 stations with up to six applicators, and the machine's small footprint allows it to slip easily into your line. The Rotary 9000's innovative tool-less change parts mean more uptime from faster and easier change-overs. The Rotary Series 9000 can also be outfitted with Label-Aire's full range of New Generation 3100 Series applicators allowing you to take advantage of this applicator line's advanced features such as automatic setup for easy change-overs, Automatic Speed Following (ASF) for added label placement accuracy, and stepper motor power for wider range speed variability and lower maintenance.

Our Rotary Series 9000 labeling system applies a wide variety of labels to products in a wide variety of industries. You can count on the Label-Aire Rotary Series 9000 to give you more.

Rotary Series 9000 Advanced Features	
Applies labels to a variety of products	The 9000 can be configured to handle four panel, neck-on-oval, semi-oval, triangular, three panel, or safety seal (tamper-evident) labeling.
Swing arm control panel	Operator control panel mounted to 270° goose neck for easy accessibility from all sides.
Label-Aire New Generation 3100 Series Primary Applicators	For precise and reliable labeling with easy set-up and change-overs and quicker line speeds. Select from four advanced models: 3115 Wipe-On, 3125 Wipe-On, 3135 Wipe-On, or 3155 Wipe-On.
Tool-less change parts	Result in reduced downtime and simplified change-overs.
Product orientation	Labels are applied at precisely the same place on every container.
Optional airfill capability	Ability to label thin walled empty containers by adding rigidity.

beverage, cd / dvd, coupon / promotional, dairy, direct mail, durable goods, food, health & beauty, nutraceutical, pharmaceutical, tamper-evident labeling

Series 9000

accuracy
(.8 mm)
applicators

Swing arm
control panel

Labeling speeds up to
600 cpm

Product orientation for
added consistency

4 to 40 stations

Tool-less changeovers

Rotary Series 9000 Labeling System

www.label-aire.com

 **label-aire**[®]
labeling made easy

Rotary Series 9000 Specifications

Number of Stations:

4 to 40

Conveyor Dimensions:

Height: 34" to 38" (864 mm to 965 mm)

Length: 140" (3,550 mm)

Width: 125" (3,175 mm)

Drive:

1.5 to 2.5 hp inverter drive

Feedscrews:

Single feedscrew with soft-start controls and product back-up sensor with integral pneumatic bottle gate

Label Placement Accuracy:

+/- 1/32" (0.8 mm)

Electrical:

220 VAC, 3-phase standard
(other voltages optional)

Applicator Options:

Label-Aire Models: 3115, 3125
3135, or 3155 Wipe-On

Options:

Air-fill capability
Motorized top bell adjustment
Touch screen operator interface
Swing arm mounted overhead controls
360° electronic perimeter guarding
Consult factory for additional options.

10-station
configuration shown

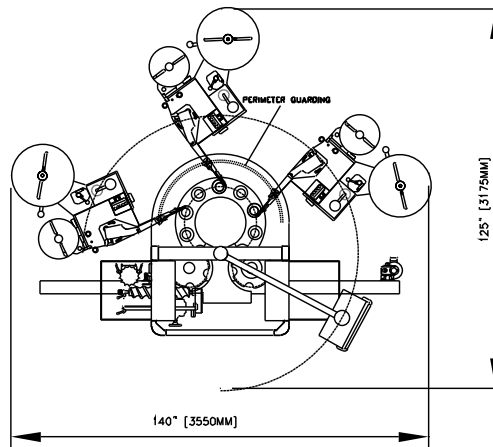
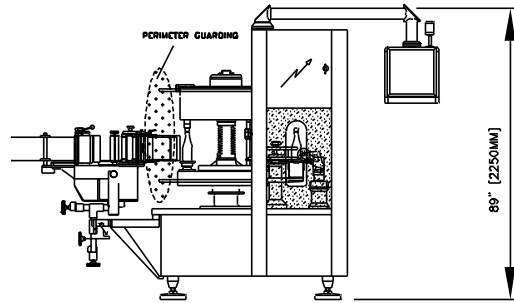

Inches
[millimeters]



QLC

537 Progress Drive
Hartland, WI. 53209

Phone: (262) 367-1 400

Fax: (262) 367-1 405

Toll Free: (800) 837-1 309

Email: info@qlc-labeling.com