

high resolution hot melt inkjet printers ■ ■ ■



Our technology ■ ■ ■

The 5800 large character inkjet printer represents the next generation of Touch Dry® Hot Melt technology delivering a superior print quality coding solution for your corrugate cases, trays and wrapping films.

Markem-Imaje Touch Dry® Hot Melt inks are solvent free and environmentally friendly. Codes and images never bleed or fade, dry on contact and deliver 100% readable, GS1 compliant codes.

Your benefits ■ ■ ■

Performance – Touch Dry® Hot Melt inks print on a wide range of substrates and in environments ranging from 0 to 40 °C. The printer, boasting print speeds up to 120 meters/minute, can be equipped with optional printhead slide assembly optimizing both print gap control and print quality.

Flexibility – Cutting-edge communication capabilities include color touch screen, Ethernet, USB, and web user interface, providing increased flexibility and functionality to end users, integrators and OEMs. Optional CoLOS® Enterprise networking software is available for central management of data from remote databases or ERP systems. Compact, modular design for stand-alone operation or complete integration.

Efficiency – Advanced printer design provides quick start up and minimizes overall energy consumption. Uptime features include a unique programmable self maintenance system and ink reloading capability during operation. Touch Dry® solid ink blocks are easily handled for simple and trouble free operation.



markem·imaje

a **DOVER** company

5800 specifications ■ ■ ■

Print features ■ ■ ■

- Printhead dpi
Vertical dpi: 200
Addressable Jets: 256
Nozzles: 512

Print Density	DPI	maximum speed (meters/min)
1	150 x 200	120
2	300 x 200	60
3	450 x 200	40
4	600 x 200	30
5	750 x 200	24

- Print densities available: 1 to 8
- Encoder scaling: Allows for conveyor line speed matching and for higher print speeds with a reduction in print resolution
- Print area: Maximum/printhead print height: 65 mm Print length: 1,000 mm
- Print specification: Full true type font supported
- Printing of real-time clock (hr/min), dates and auto updating best before dates and serial numbers
- Barcodes (Linear and 2D): ITF, Code 39, Code 128, EAN 128, EAN 8, EAN 13, UPC A, UPC E, Data matrix, RSS linear, RSS composite, QR, RSS 14, RSS expanded, PDF 417

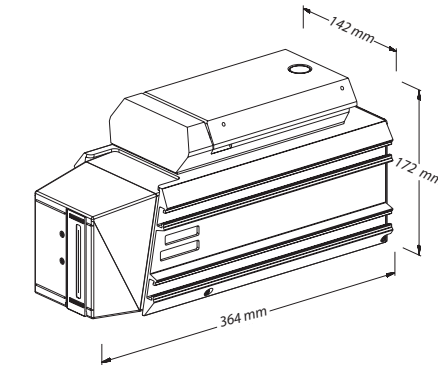
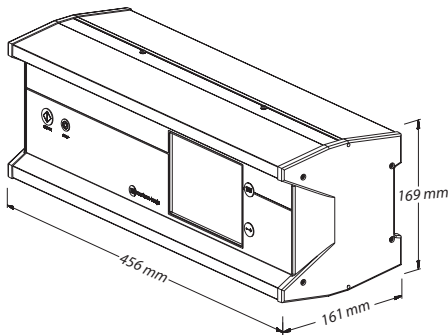

Operations ■ ■ ■

- 5800: Up to two printheads
- User interface: Color LCD touch screen used for image selection, variable data entry, diagnostics and system setup.
- Selectable multi-language menus
- Image preview
- Access level password protection
- Full system diagnostic menu
- Printhead orientations: Vertical or up to 20° of process direction
- Software:
 - CoLOS® Create image design software included
 - CoLOS® Create Pro (Optional)
 - CoLOS® Enterprise for networking (Optional)
- Encoder options:
 - Internal: For fixed conveyor speed printing
 - External: For optimizing print quality Recommended for barcode printing
- Photo-edge sensors: Print (trigger) signal and a maximum of two per system
- Software interface:
 - USB for downloading images, settings and data files
 - Ethernet (including web user interface)
 - Communications protocols for PCs, PLCs and packaging machines
 - Compatible with Weihenstephan standard
- Hardware outputs: (3) Fault relay
- Ink replenishment: User prompted to add ink; can be filled without the need to suspend printing
- Interfaces: Hand held product select scanner

Other characteristics ■ ■ ■

- Weight: Printhead: 7.2 kg
Control box: 11.2 kg
- Touch Dry® hot melt inks: Available in various series, colors
- Electrical and environmental:
100-240 V 50-60 Hz

System	Measured Operating Power	Peak Power During Warm-up
1 head	150 watts	600 watts
2 heads	250 watts	600 watts
3 heads	400 watts	600 watts
4 heads	500 watts	600 watts

CE Marked. ETL listed, conforms to ANSI/UL 60950, 3rd edition (2000); CAN/CSA No. 60950-00, 3rd edition (2000).

- Operating environment of 0 to 40 °C (32 to 104 °F). IP42 (controller only)
- Manuals: Instruction manual and CD-ROM User Guide (includes spare parts, options, and accessories Catalog)
- Local language versions for the color user interface
- Regional telephone technical and product support
- Web site technical and product support

Options ■ ■ ■

- Printhead slide assembly
- Signal tower assembly
- Post print barcode scanner assembly
- TU Look-up assembly
- Optional expansion unit (OEU) - support 11 inputs, 8 outputs and 1 additional scanner port
- Printer service kits
- Preventive maintenance kits and contracts
- On-site product and tech support

To learn more, visit www.QLC-labeling.com



The design and manufacturing plants of this product are
ISO 9001
CERTIFIED

We reserve the right to amend the design and/or specifications of our products without notice.

QLC, Inc.
537 Progress Drive
Hartland, WI 53029
www.QLC-labeling.com

(800) 837-1309



markem·imaje

a **DOVER** company