

### Thermal Transfer Overprinting

Designed for medium-duty applications, the SmartDate X45 delivers high-quality coding on flexible film packaging up to 220 packs per minute. Its fully intuitive 10.1" user interface makes daily operations easy and straightforward while providing the most valuable information you need to optimize and improve your Overall Equipment Effectiveness (OEE) through MI Sigma reporting.

### Enhanced SmartDate experience

- Optimized tracking of OEE data**  
 Coder can be configured to monitor your 5 most important production metrics directly from your home screen e.g., pack rate, throughput, availability.
- Tutorials to facilitate daily activities**  
 Animated help and 'how to' tutorials provide guidance on setup and daily maintenance procedures to ensure consistent print quality.
- Profile configurator for error-free operation**  
 Configurable profile password function (operator, supervisor and engineer) manages access and limits human-related errors.



A 10.1" color user interface offers a fully intuitive user experience to provide simple operation in just a few clicks.

### High-performance printing

- Supports your marketing campaigns**  
 Promotional coding function\* allows for unique coding on each pack.
- Eliminates faulty codes and protects your brand**  
 In addition to its dead-dot detection system, the easy-to-install SmartDate Detect-Plus system\* checks and confirms the presence, position and quality of the code on every pack and directly on the user 10.1" interface.
- Achieves superior printing speeds**  
 Print speed can be set from 30 mm to 600 mm per second allowing for 220 printed packs per minute at 300 dpi.



Ideal for multiple line coding including text, logos, and barcodes.

### Unmatched and cost-effective reliability

- Zero preventive maintenance**  
 Robust direct ribbon drive and cassette design contain no wear parts.
- Adapted for your production line**  
 Choice between intermittent or continuous configurations and 32 mm or 53 mm printheads.
- Up to 15%\*\* more codes per roll**  
 Large choice of ribbon rolls based on your packaging type and needs.



Three ribbon types available: SmartDate Xtra, SmartDate Xceed and SmartDate Xpert.

\*Optional \*\*Compared to other competitive models.

# SmartDate X45 - Specifications

## Print features

- Print speed:
  - Intermittent: up to 600 mm/s
  - Continuous: 30 to 600 mm/s
- Print area:
  - Intermittent: 32 mm or 53 mm x 75 mm
  - Continuous: 32 mm or 53 mm x 250 mm
- Print features:
  - Automatic printhead setup
  - Detect: Dead-dot detection
  - Quick change printhead
  - Intermittent or continuous printing
  - Easily change from left to right hand with no additional parts
  - Gap between prints: 0.5 mm
  - Automatic shift codes and serial numbers
  - Multiple variable user input fields with alphanumeric texts
  - High-pack-rate mode
- Ribbon-saving mode: Radial ribbon save, Interlaced mode, Radial mode 1, Radial mode 2, Radial interlaced, Whitespace, Radial whitespace, and Step advance
- Print specifications: Full TrueType font support, including non-Roman characters and symbols. Printing of real-time clock, dates and auto-updating best before dates, barcodes: ITF, Code 39, Code 128, EAN 128, EAN 8, EAN 13, UPC A, UPC E, RSS linear, PDF 417, GS1 DataMatrix, QR and Composite RSS barcodes support

## Operations

- User interface: 10.1" full colour 1024 x 600 touch screen for message selection, variable data entry, diagnostics and system setup
- MI Sigma functionality
- Advanced health and availability monitoring
- Configurable user home screen
- Animated help tutorials: ribbon fitting, printhead cleaning, printhead replacing
- Simple print adjust
- Parent/Child function to allow parent control for up to 7 children
- Configurable password protection capability
- WYSIWYG print preview of printed message, real-time display of remaining print capacity expressed in hours and number of prints
- Full diagnostics (pack rate, speed)
- Robust LED status indicators on the printer
- Webbing diagram for fast ribbon changes
- Hardware interface: Inputs: "print go" and 1 configurable input  
Outputs: fault, warning, and 2 configurable outputs
- Software interface: USB for downloading images, settings and data files. RS232, Ethernet communications standard. Communications protocols for PCs, PLC and packaging machines, including full remote control web server

## Other characteristics

- Supplies: thermal transfer ribbon available in a variety of grades and colors
- Maximum ribbon length: up to 1100 m
- Minimum ribbon width: 20 mm
- Maximum ribbon width: 55 mm
- Weight: Printer: 7.8 kg, Color controller: 4.5 kg
- Electrical power supply: 90 – 264 V with automatic switching; frequency 47/63 Hz; power 150 VA
- Air supply: 6 bar/90 psi (maximum) dry, uncontaminated
- Air consumption: down to 0.4 ml/print at 2.5 bar
- Operating temperature range: 0 to 40°C
- Humidity: 10% to 90% non-condensing

## Optional accessories

- Detect-Plus: code detection
- Promotional coding
- WEB Browser and Virtual Network Computing support
- Mounting bracket
- Encoders
- IP protection kit for installed SmartDate X45

## Software

- Included, CoLOS® Free 6.0 for design of simple messages

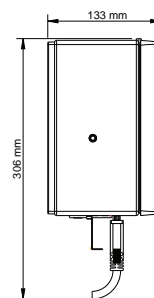
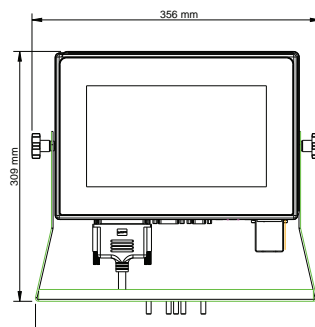
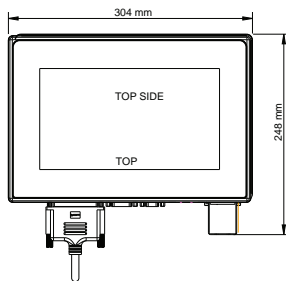
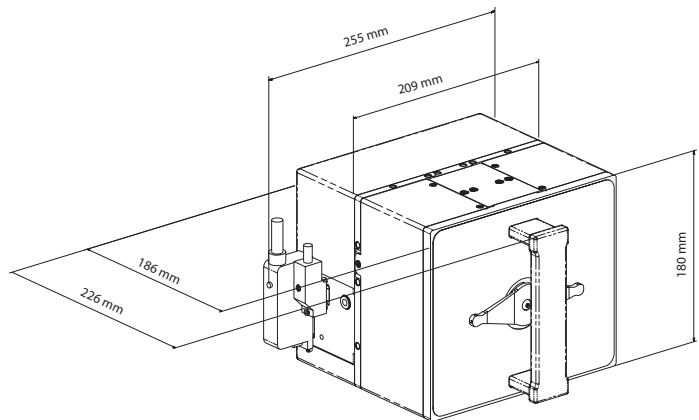

We reserve the right to amend the design and/or specifications of our products without notice.  
© 2020 Markem-Imaje. All rights reserved.

**QLC, Inc.**  
**537 Progress Drive**  
**Hartland, WI 53029**  
**(800) 837-1309**

  
**markem·imaje**  
a **DOVER** company

To learn more visit [www.QLC-Labeling.com](http://www.QLC-Labeling.com)