

Instruction manual

9750



Printer overview	2
Interface overview	5
Presentation of the menus	6
Starting up the printer	8
Shutting down the printer	9
Sending a job for printing	10
Modifying a job	12
Modifying a job in progress	14
Information on consumables	15
Replacing the consumables	16
Head Maintenance	18
Troubleshooting	20
Information	21



markem·imaje

a **DOVER** company

for parts & service call QLC (800) 837-1309

Printer overview

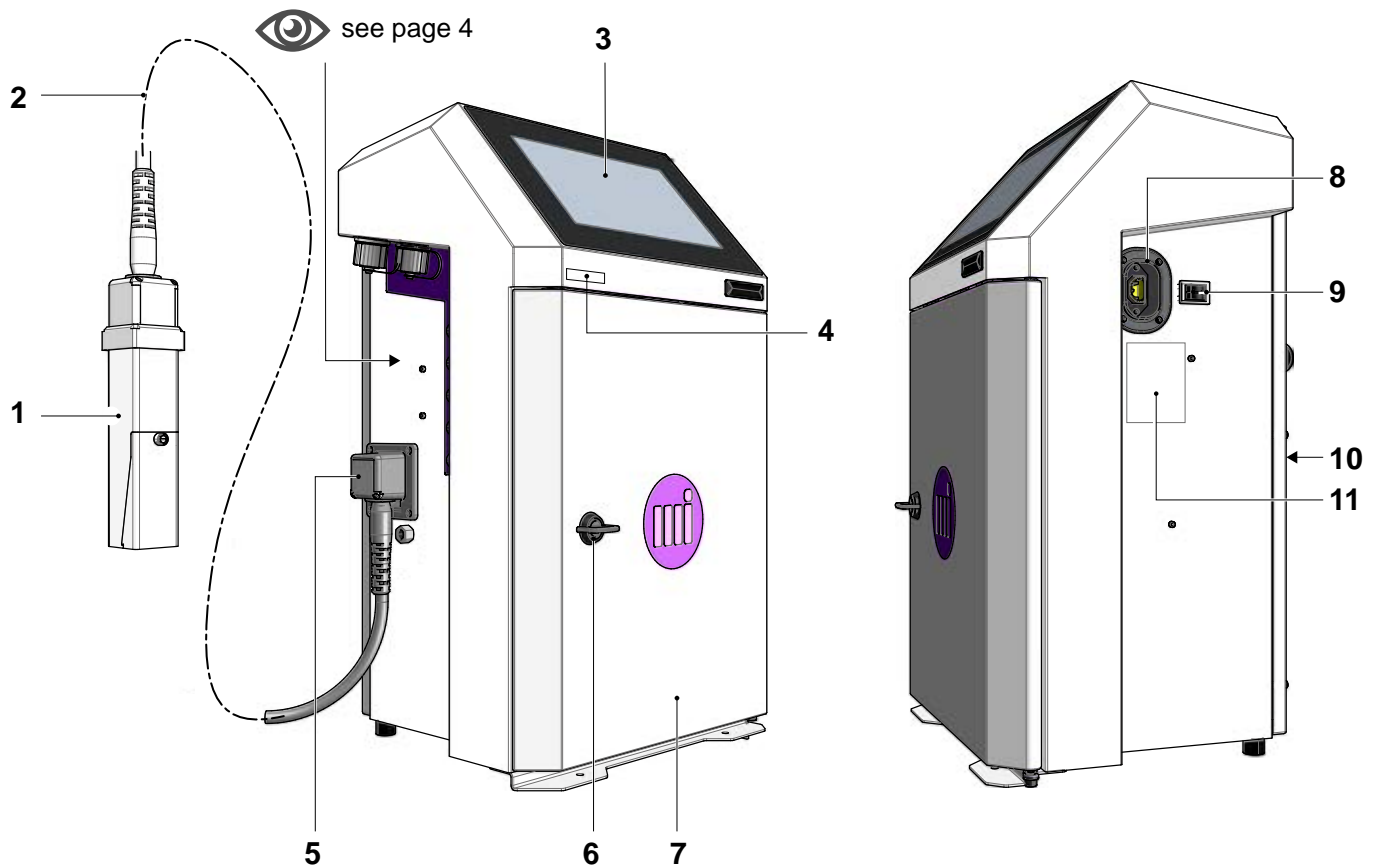

1	Printhead
2	Umbilical
3	Operator interface
4	Identification label (serial no.)
5	Umbilical outlet
6	Handle for opening the door
7	Access door for consumable parts and maintenance modules
8	Electrical socket
9	ON/OFF switch
10	Access to hydraulic/electric/electronic components
11	Identification label

Printer overview

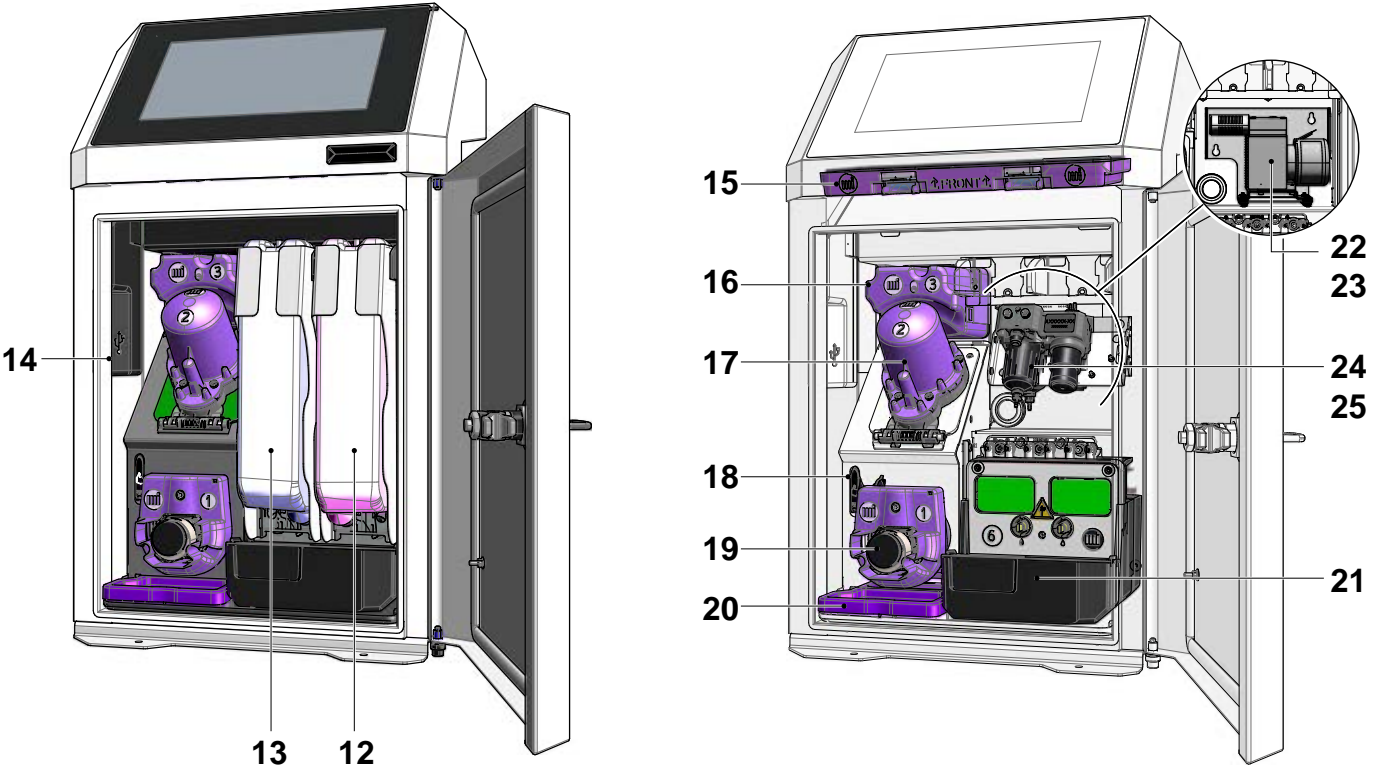

- 12 Additive cartridge
- 13 Ink cartridge
- 14 Internal USB port
- 15 Module 4 - Air in filter IP56 (violet)
- 16 Module 3 - Recovery pump/Venturi
- 17 Module 2 - Filter for the primary ink
- 18 Manual maintenance valve
- 19 Module 1 - Pressure pump
- 20 Module 5 - IP56 air out filter (violet) or non-removable IP66 filter (depending on the version)
- 21 Module 6 - Equipped hydraulic module
- 22 Standalone compressor kit module (optional)
- 23 Filter-silencer cartridge for the standalone compressor
- 24 Air Treatment Kit module (optional)
- 25 Filter cartridge for Air Treatment Kit module

Printer overview

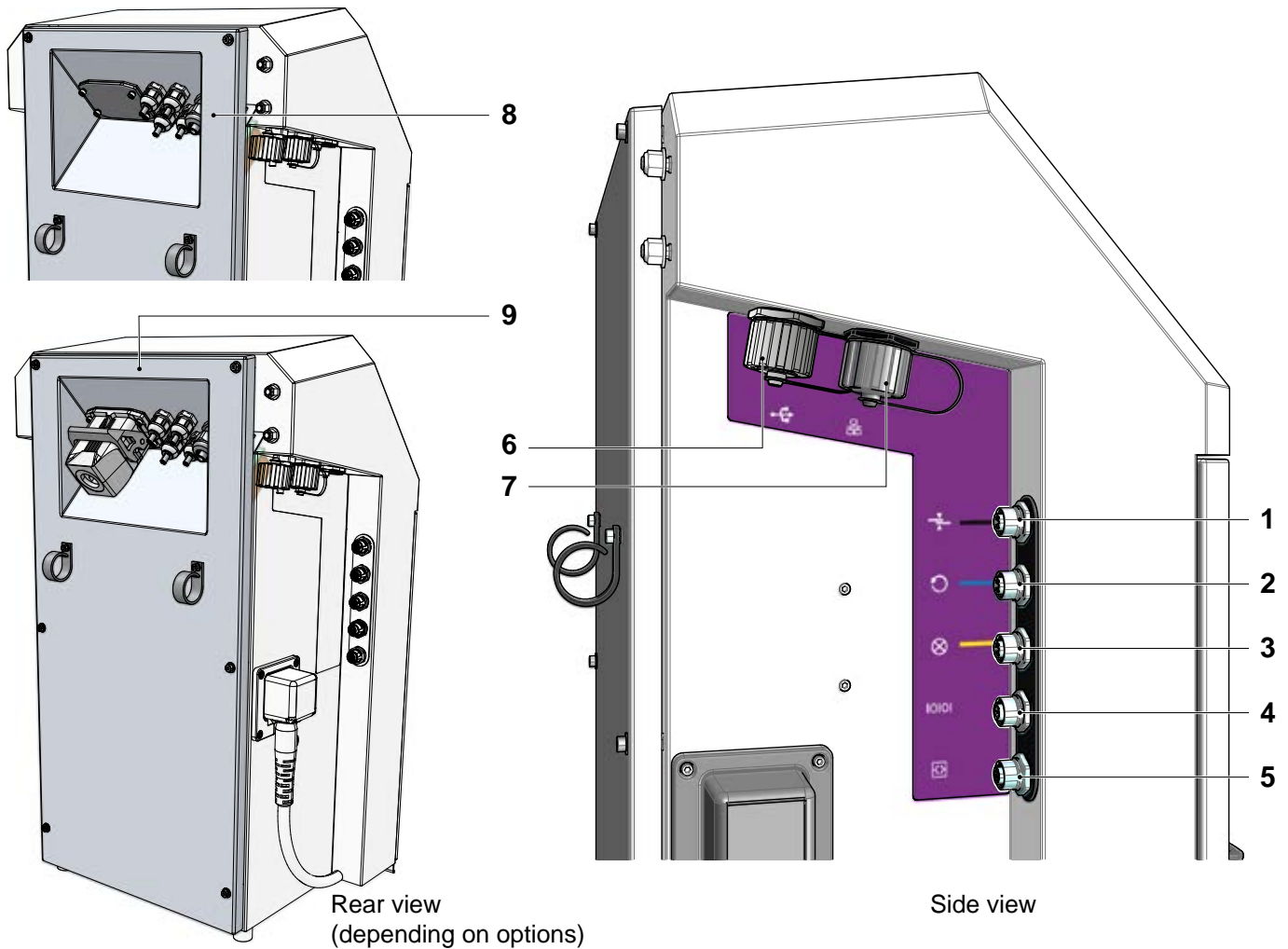

- | | |
|---|---|
| 1 | Cell input M12 socket (black) |
| 2 | Encoder input M12 socket (blue) |
| 3 | Warning light output M12 socket (yellow) |
| 4 | Serial link RS232 connector M12 socket |
| 5 | Configurable I/O M12 socket |
| 6 | External USB port |
| 7 | Ethernet connector |
| 8 | Rear panel with Industrial interface card (4 cable glands - Serial/ Parallel and Ethernet link) - Optional |
| 9 | Rear panel with Industrial interface card (4 cable glands - Serial/ Parallel and Ethernet link + 24-pin connector) - Optional |

Interface overview

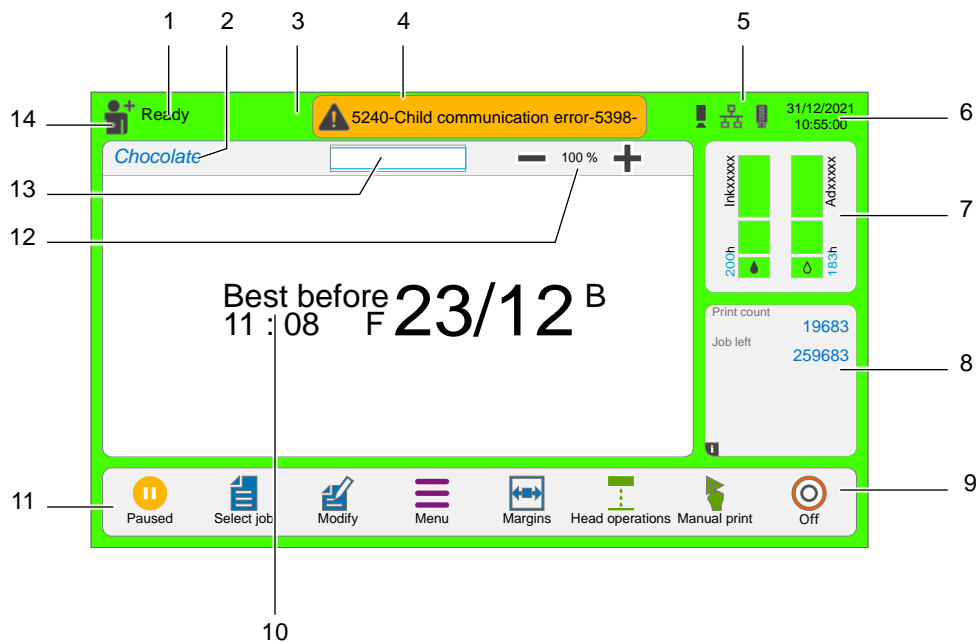

1 Printer reports

2 Name of the job being printed

3 Coloured background. Printing status

4 Coloured bar. Information on alarms or faults

5 External equipment connection indicator

6 Current date and time

7 Consumable part level indicator and access to more information

8 Customisable information display. Access to 3 production and operation information screens.

9 Start/Stop printer

10 Preview of the job being printed

11 Icon bar

12 Increase or decrease display size

13 Navigation window

14 Selected profile display. Access to change profiles

External equipment connection indicators:



Printer connected to the network ('Child')



USB key connected



'Parent' printer



Camera statuses

Presentation of the menus

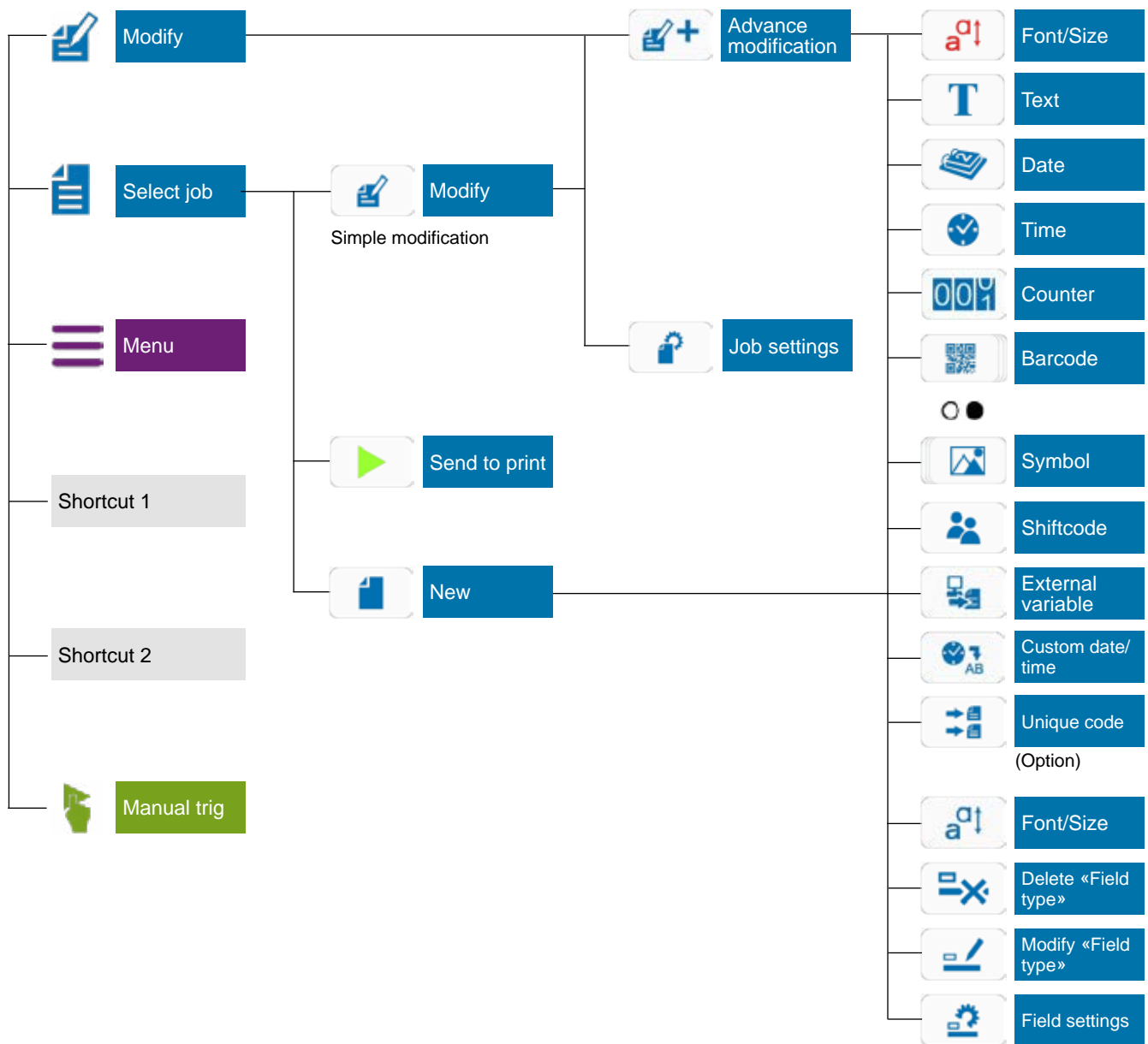

Presentation of the menus

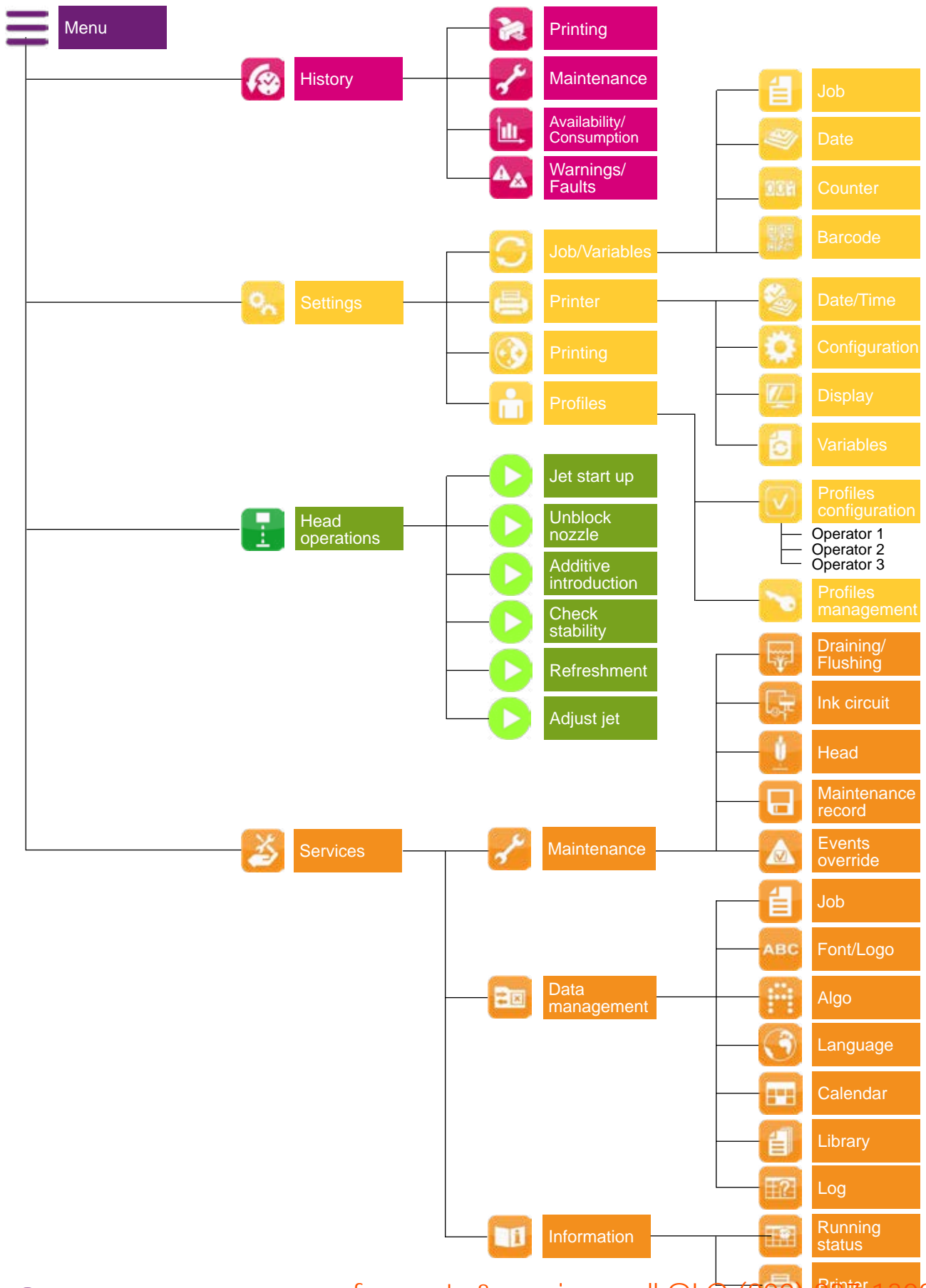

Starting up the printer

1

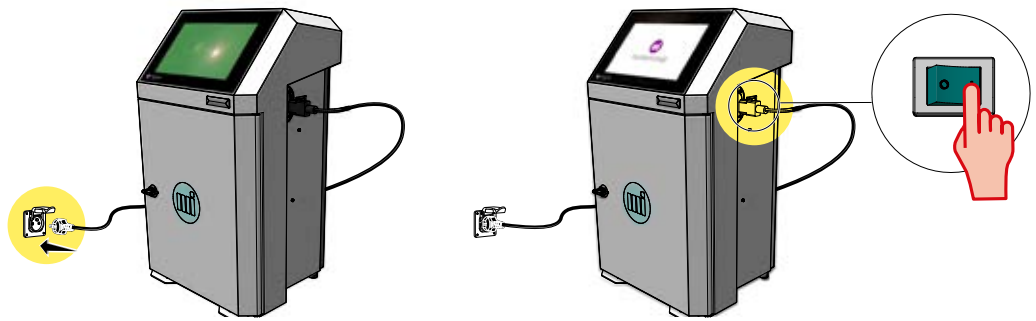

2



Printer stopped

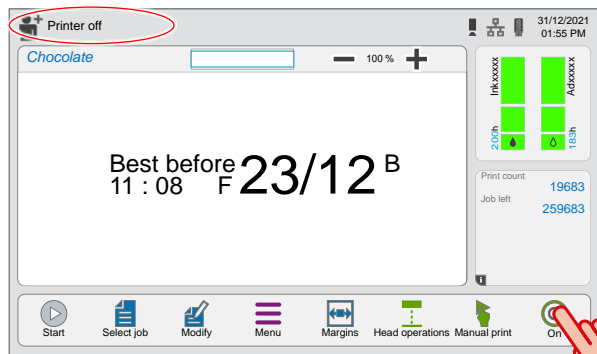

3



Confirm printer start instruction.

Start-up in progress

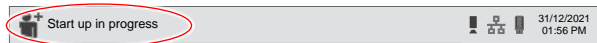

Jet start-up in progress

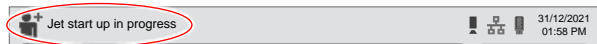

Ready to print the 'Chocolate' job displayed.

The screen's background turns green.

Ready

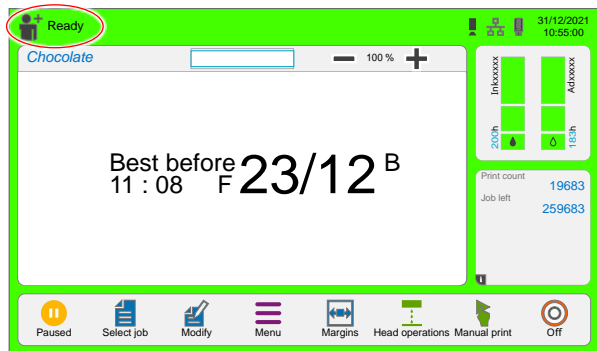

Shutting down the printer

1

Ready

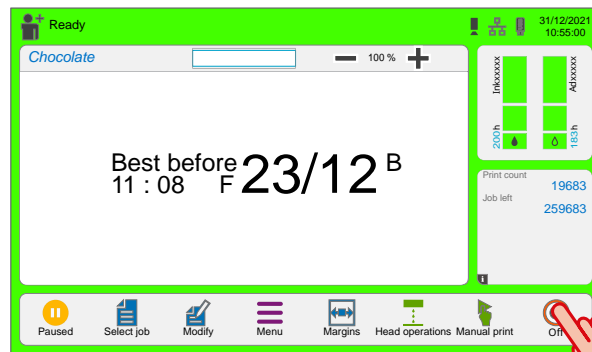

2

Confirm printer stop instruction.

The screen's background turns grey.



Jet stopped

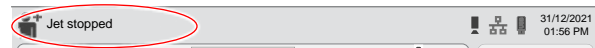

Stopping

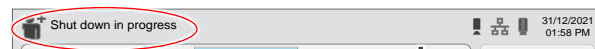

Printer stopped

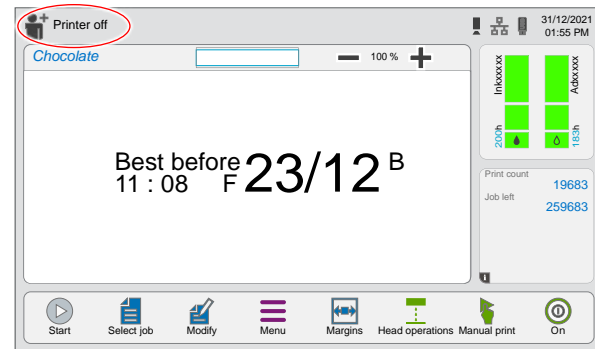

3

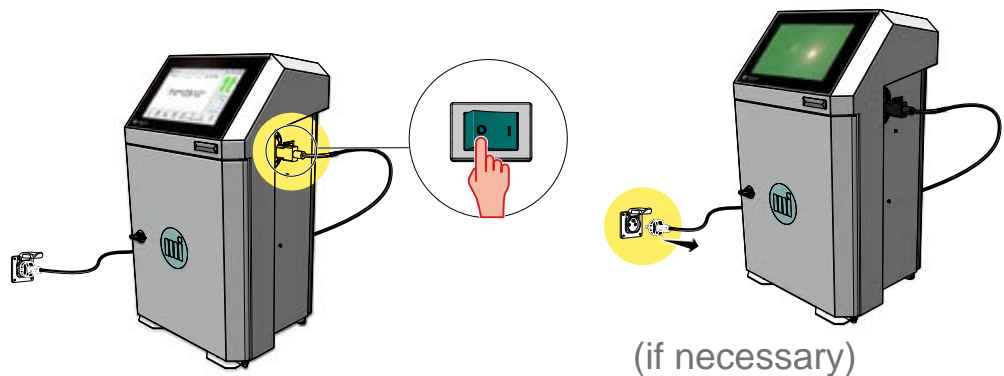

Sending a job for printing

1

Ready

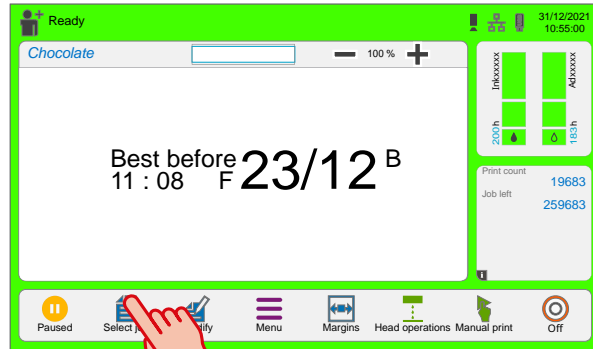

2

Select a job

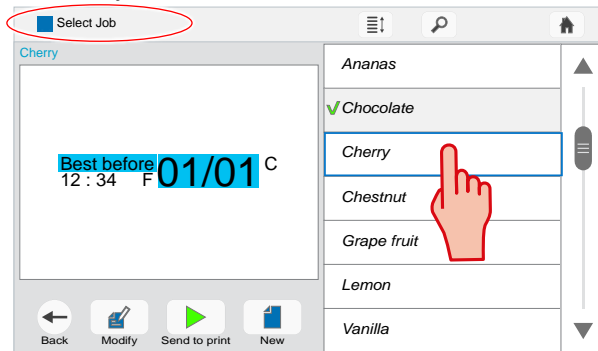

3

Select a job

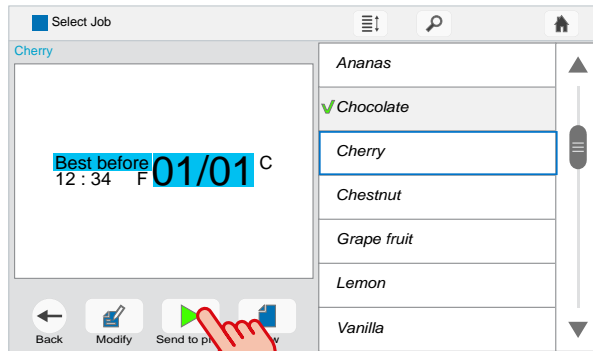

Ready



Sending a job for printing

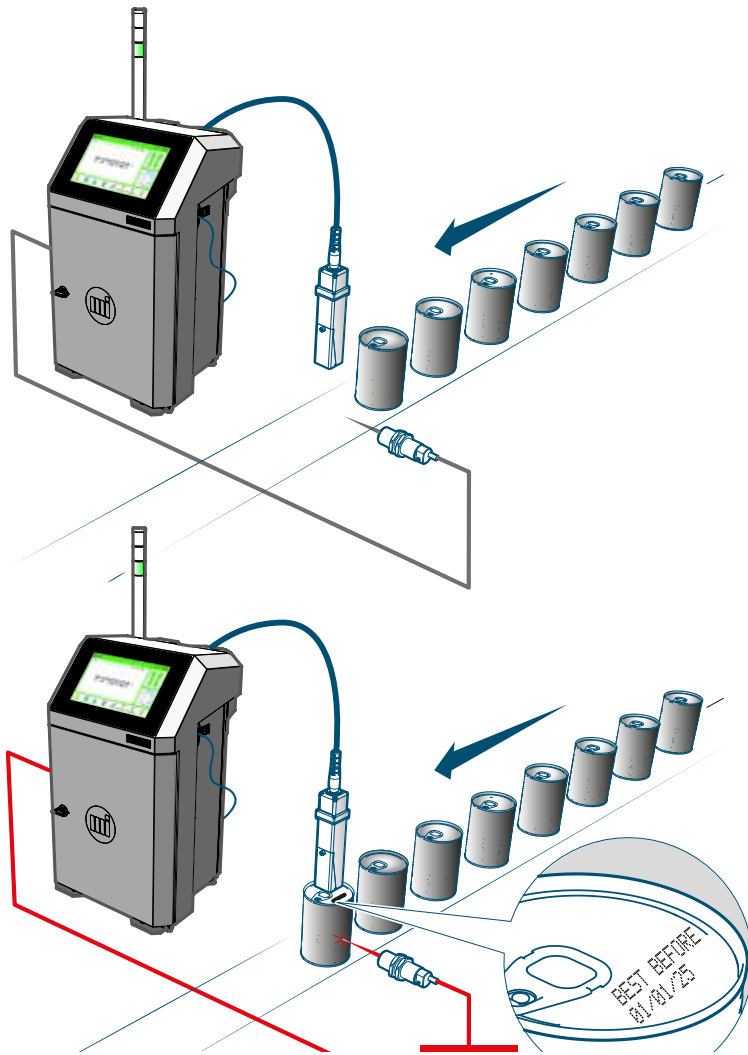

Suspend printing:

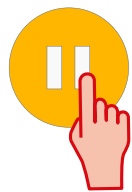

Printing paused

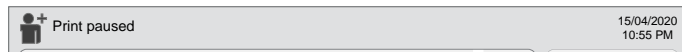

Resume printing:

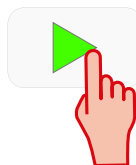

Ready



Modifying a job

1  Modification of the job in production

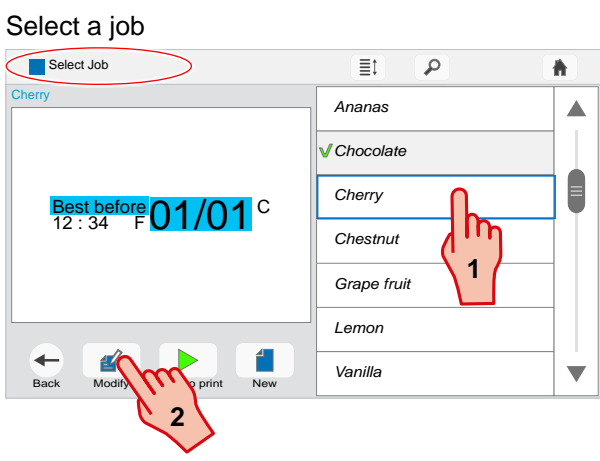
2 

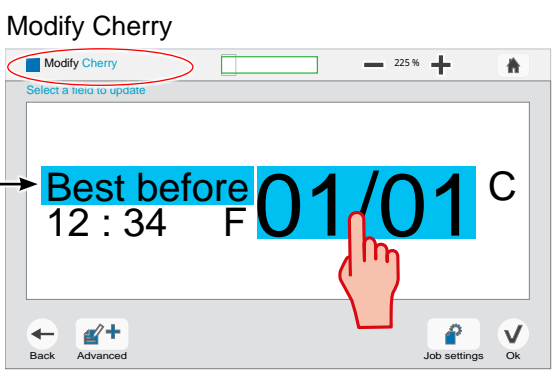
3  Modifiable fields

4  Text modified

Modifying a job

5

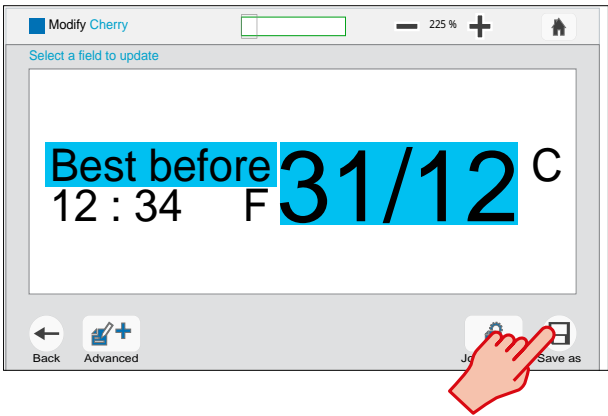

6

Confirm the modification.

7

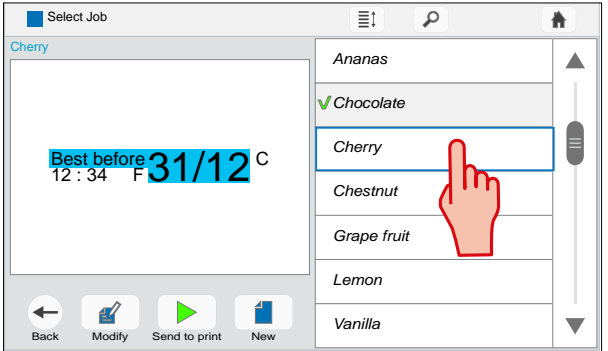

Modifying a job in progress

1



Modification of the job in production

OR

Press and hold the job you want to modify



2

Repeat from step 3 of 'Modifying a job'.

Information on consumables

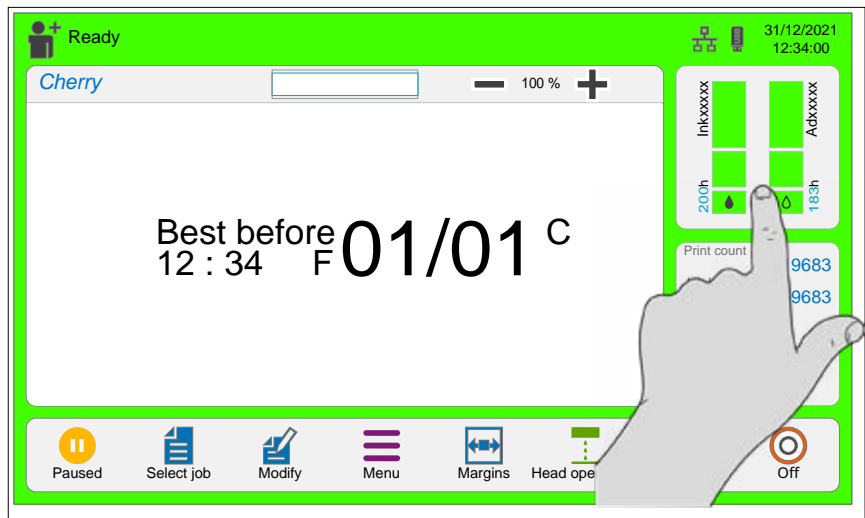

1 Ink cartridge information area

2 Additive cartridge information area

3 Ink/additive references detected
 - Black text: OK
 - Red text: bad cartridge
 - Other text: the inserted cartridge is not a Markem-Imaje cartridge.

4 References expected by the printer

5 Cartridge batch number

6 Cartridge expiration date
 - Blue text: OK
 - Red text: out of date

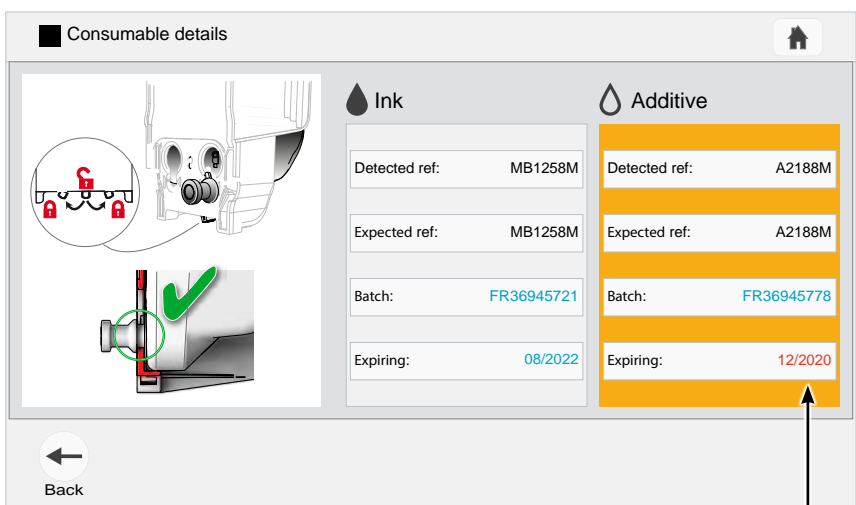
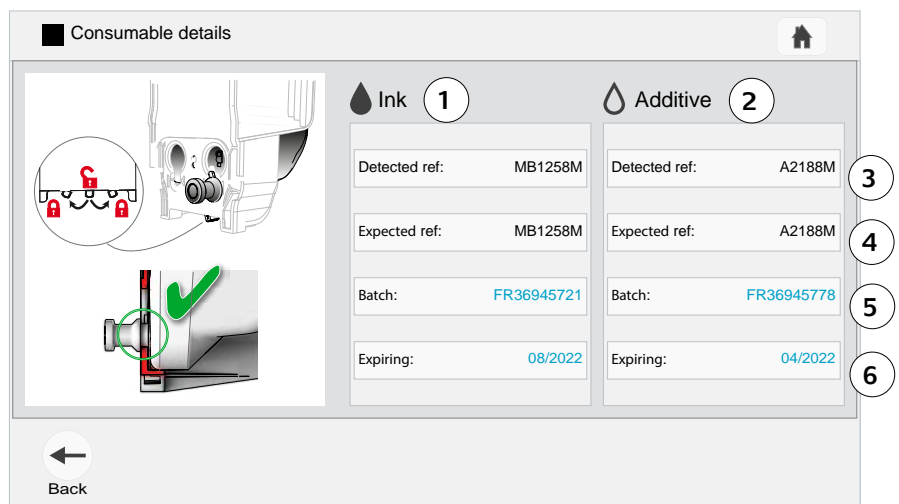

The date has passed

If the printer detects a problem with any of the cartridges, the background turns orange.

for parts & service call QLC (800) 837-1309

Replacing the consumables

Only if:

 Replace ink cartridge

 Replace additive cartridge

OR

OR

OR

 Replace ink cartridge

 Replace additive cartridge

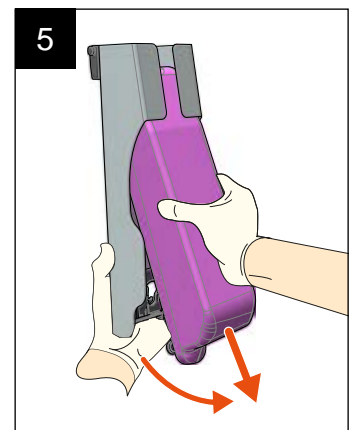
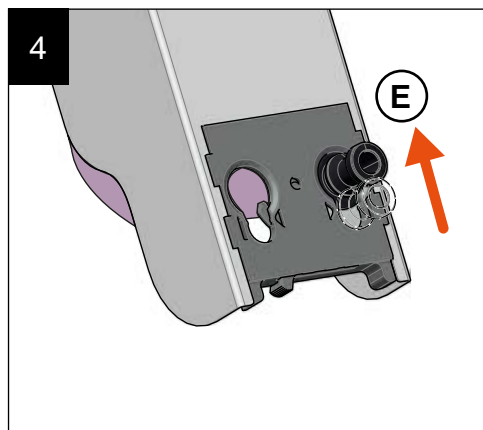
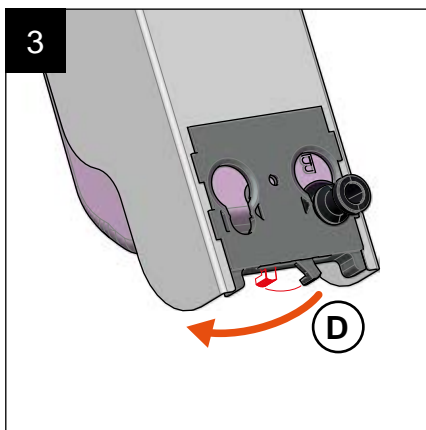
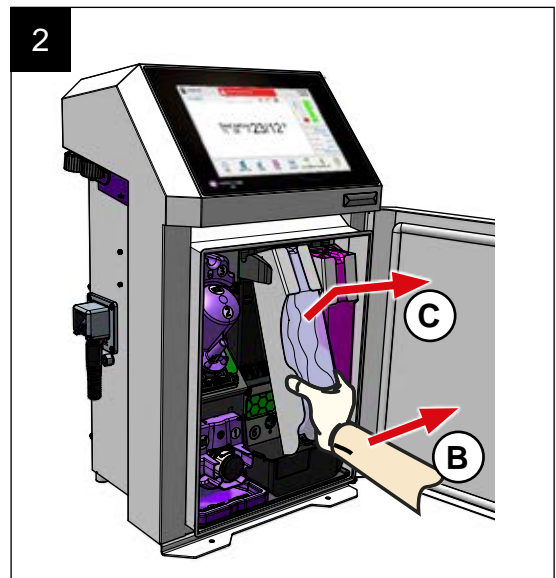
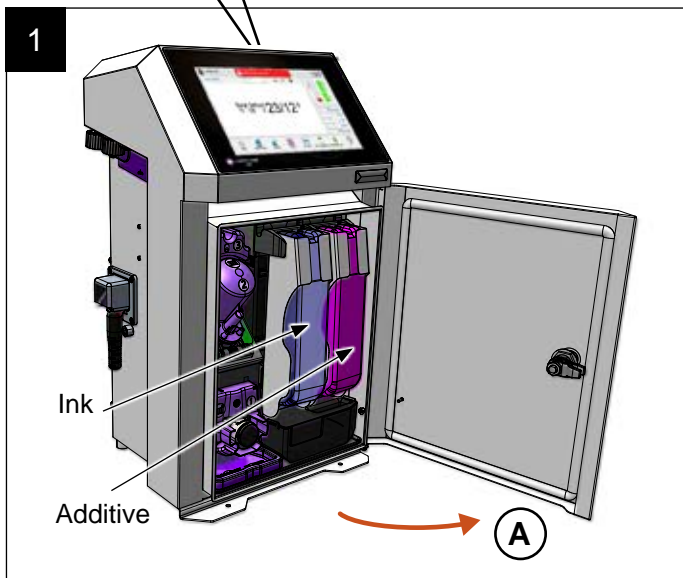

'Waste and Consumable Parts'
Safety and important information



Replacing the consumables



Pigmented ink: Shake vigorously until the deposit disappears completely.
Only use Markem-Imaje consumables.



WARNING
Risk of puncture
When replacing the cartridges, do not touch the nozzle.

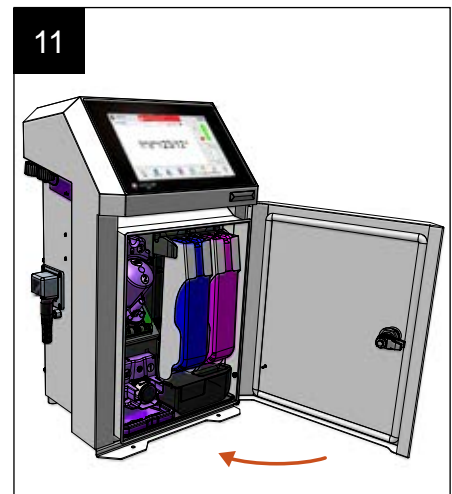
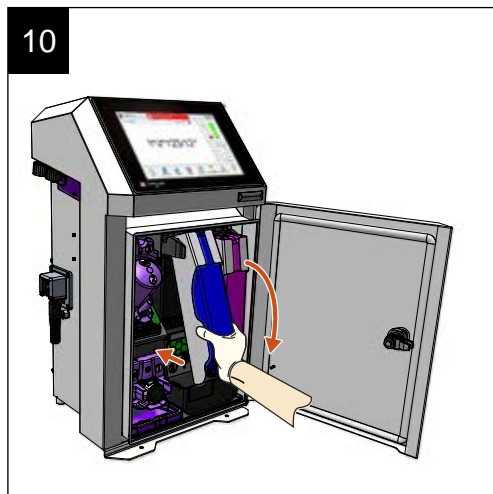
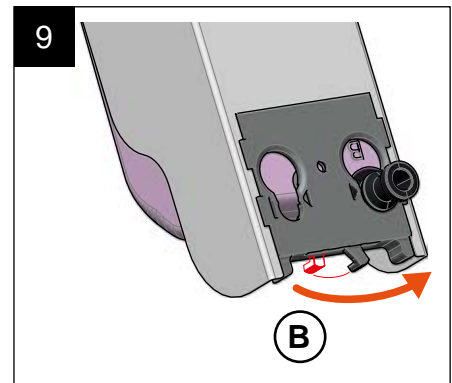
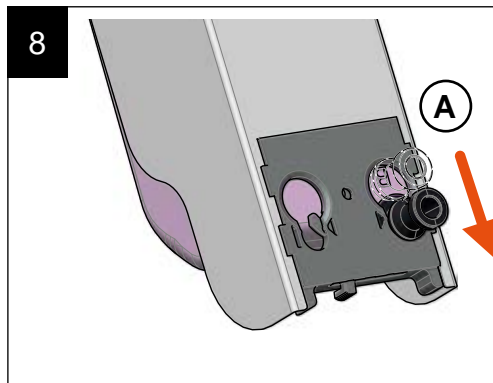
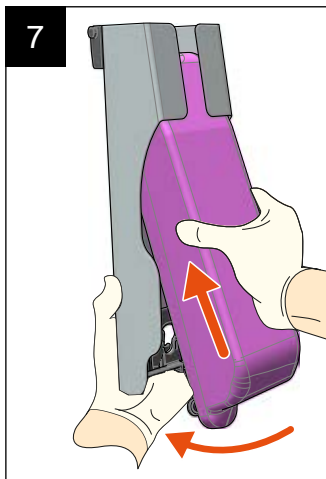
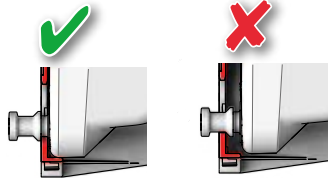

After the new ink cartridge is inserted, it empties partially into the printer's internal tank.

Head Maintenance



1

Stop the jet:

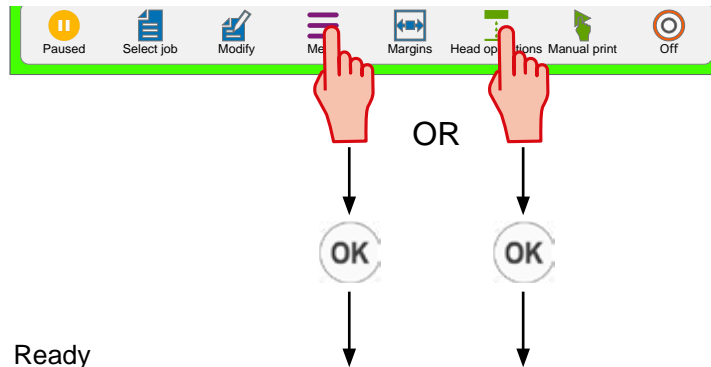

Ready

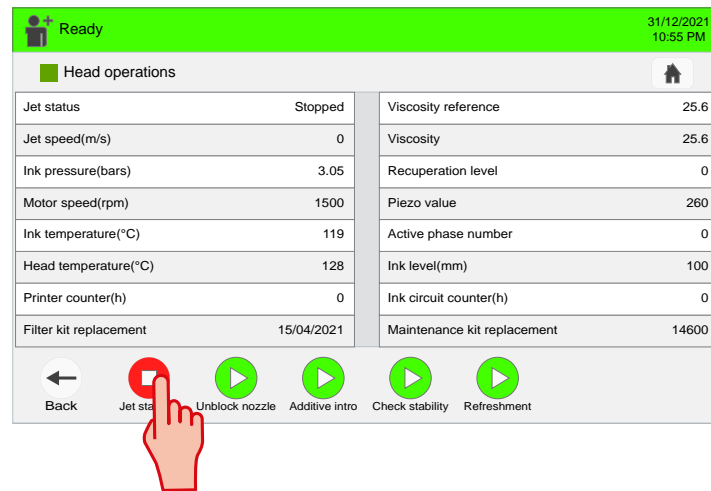

Jet stopped



2



Only use Markem-Imaje cleaning fluid.

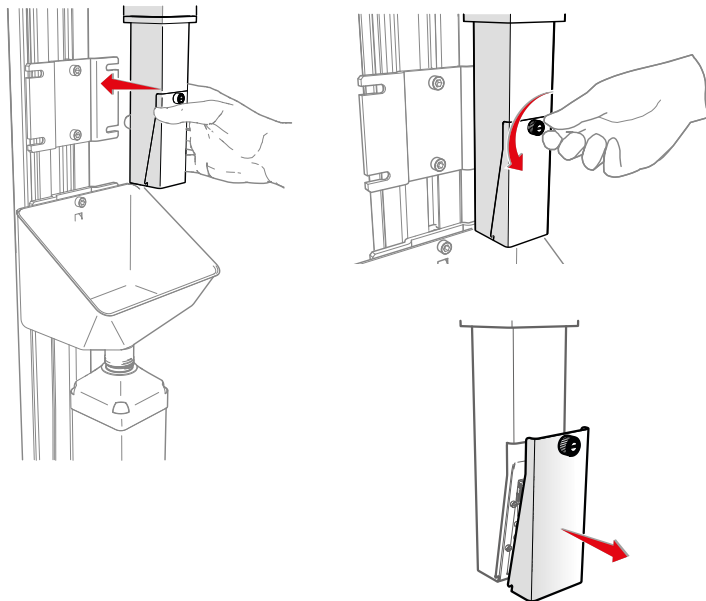

Head Maintenance

3

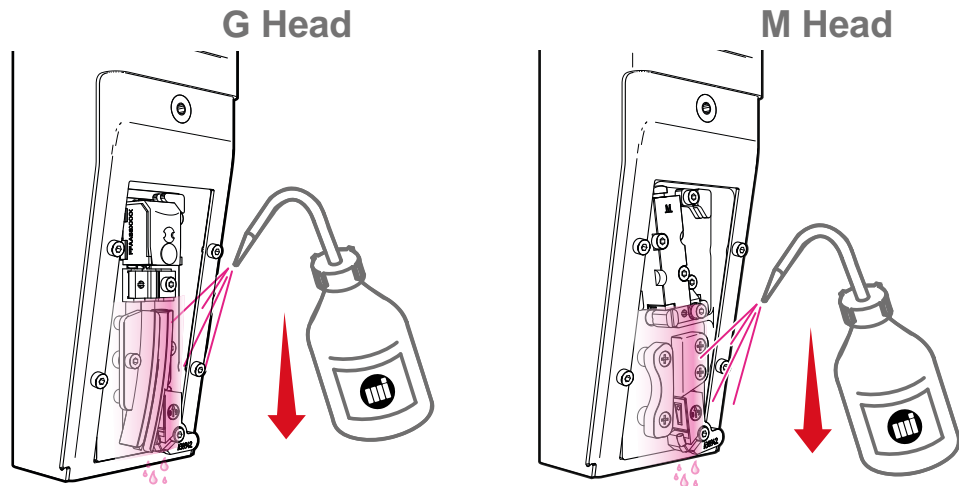

4

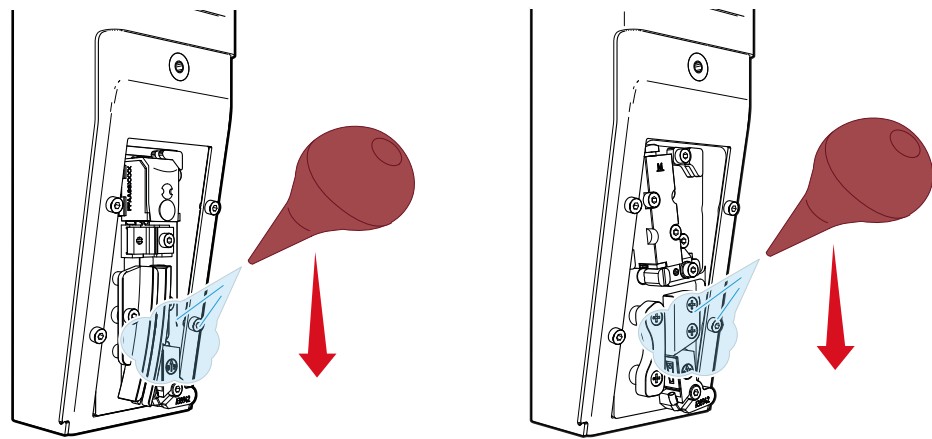

5

Jet stopped

Jet stopped 31/12/2021 10:55 PM

Head operations

Jet status	Stopped	Viscosity reference	
Jet speed(m/s)	0	Viscosity	
Ink pressure(bars)	3.05	Recuperation level	
Motor speed(rpm)	1500	Piezo value	260
Ink temperature(°C)	119	Active phase number	0
Head temperature(°C)	128	Ink level(mm)	100
Printer counter(h)	0	Ink circuit counter(h)	0
Filter kit replacement	15/04/2021	Maintenance kit replacement	14600



1

2

Ready 31/12/2021 10:55 PM

When using certain inks or operating the printer in harsh environments (hot and/or dusty environments), you will need to clean the head thoroughly. See user manual or Sheet A47081.

Troubleshooting

Alarm



Acknowledge the fault or alarm



Go to the troubleshooting screens (if available)



Summary of the warning/fault in the information bar.



Use your mobile phone or tablet to scan the QRcode associated with each fault.

Our virtual assistant will help you troubleshoot and solve technical problems yourself using an online help tool (Internet access required).

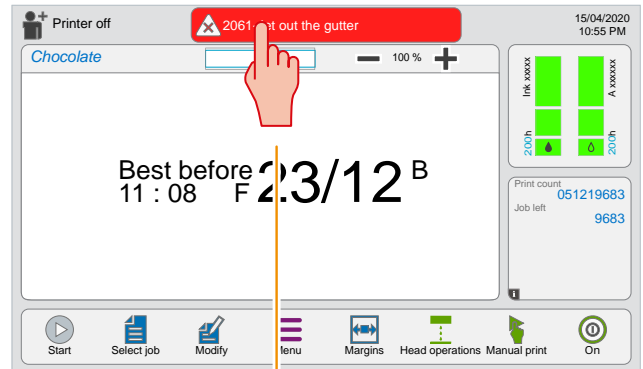

Resolve the warning or fault (access the troubleshooting procedure)

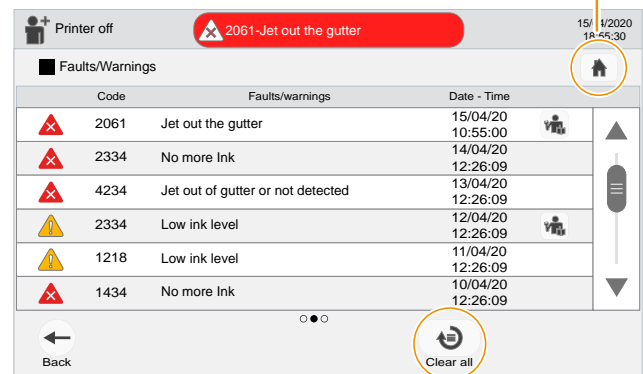

Acknowledge all warnings and faults on the list

Information for machines equipped with a light beacon (green, blue, yellow):

- The green light indicates normal conditions. (A)
- The blue light indicates a condition that requires operator action. (B)
- The yellow light indicates an abnormal condition, the emergence of a critical condition. (C)

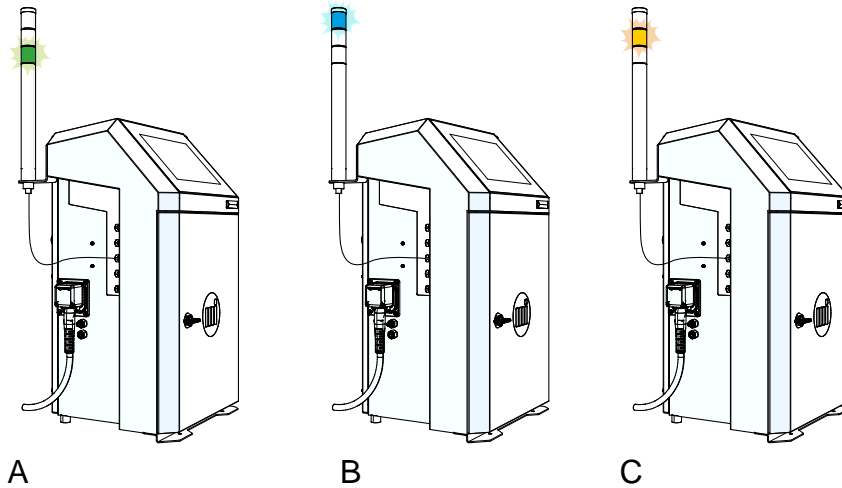

S/N: Serial number: _____

Additive ref.: _____

Ink ref.: _____



This product is for industrial use only. For Marking & Coding Equipment. Photographs and drawings are not binding in detail. Original manual. This document was originally written in French. The French text of this document shall alone be authentic and shall prevail in the event of a dispute. Markem-Imaje reserves the right to modify the specifications of its products without prior notice. Any reproduction, even partial, of this document is prohibited.

© 2022 Markem-Imaje All Rights Reserved. English version



Markem-Imaje Industries
9, rue Gaspard Monge
26500 Bourg-lès-Valence
France
Tel.: +33 (0)4 75 75 55 00

www.markem-imaje.com

10114437-AB

04/2022

en

for parts & service call QLC (800) 837-1309